

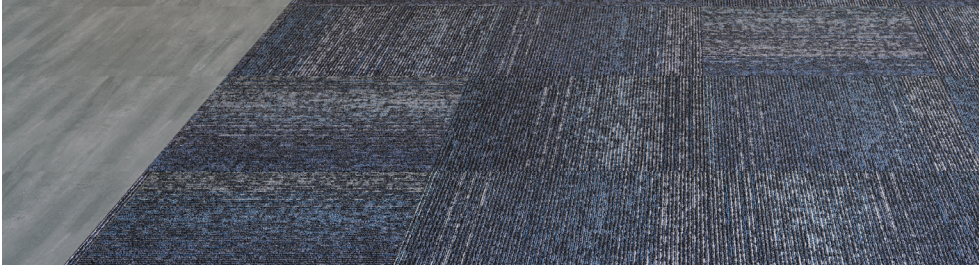

# 2023 Product Catalog



Mohawk Group



## One company. One dedicated team. One customer—You.

Mohawk Industries strives to meet or exceed all of the highest standards our government customers require for their projects. We are proud that our commitment to excellence provides an unprecedented array of styles, colors and patterns of broadloom and modular carpet as well as luxury resilient and rubber flooring for every need.

## Your challenge. Our opportunity.

We want to listen and discover how best to understand your challenges, needs and expectations. Success comes from a partnership, drawing from the combined knowledge of its team members. Mohawk is the largest flooring manufacturer in the world and will be there to make sure that your goals become ours too.

## Sustainable Leadership

Sustainability is not simply good business; it's an ongoing culture of commitment to improving the world around us. And no company understands this better than Mohawk.

Backed by a history of forward-thinking innovation, our products and people continue to positively impact the environment from every angle—including smart flooring solutions that contribute to LEED® points, technologies that reduce waste and save energy, the recycling of billions of plastic bottles every year, and donating flooring and time to “green building” projects across the country.

We're reducing our environmental footprint with every step we take, and now we're extending this philosophy to our media materials. Digital content delivery represents the first phase of what will eventually become a comprehensive online editorial resource—helping us to save paper and also your time.

### Contract Information

Contract Number: FA800322R003

Freight: FOB Destination Prepaid & Add

For Contract Information: **Sergio Blanco**  
contract\_compliance@mohawkind.com

### Placing an Order **Strategic Account Code: 14459**

This code must be used when placing an order to ensure correct reporting requirements to the Department of the Air Force. Please also reference contract number FA800322R003 on the PO.

government\_customerservice@mohawkind.com



## ORGANIC PATTERNS

### CARPET TILES

---

|  |           |
|--|-----------|
| <b>Organic Small . . . . .</b>         | <b>.1</b> |
| Caliber                                |           |
| Flux Play                              |           |
| Filtering Form                         |           |
| <b>Organic Medium . . . . .</b>        | <b>.7</b> |
| Academic View                          |           |
| Refined Pass                           |           |
| Framed Structure                       |           |
| <b>Organic Large . . . . .</b>         | <b>13</b> |
| Flux Foundation                        |           |
| Shaded Lines                           |           |
| Rise Up                                |           |
| <b>Organic Complimentary . . . . .</b> | <b>19</b> |
| Statement Stone                        |           |
| Datum                                  |           |
| Sector                                 |           |

### CARPET PLANKS

---

|  |           |
|--|-----------|
| <b>Organic Small . . . . .</b>         | <b>25</b> |
| Drifted Ground                         |           |
| Shifted Focus                          |           |
| Unexpected Detail                      |           |
| <b>Organic Medium . . . . .</b>        | <b>31</b> |
| Thematic Thread                        |           |
| Angled Perception                      |           |
| Metalmorphic                           |           |
| <b>Organic Large . . . . .</b>         | <b>37</b> |
| Hidden Dimension                       |           |
| Urban Terrain                          |           |
| Urban Transit                          |           |
| <b>Organic Complimentary . . . . .</b> | <b>43</b> |
| Color Balance                          |           |
| Disruptive Path                        |           |
| Visual Connection                      |           |

### BROADLOOM

---

|                                     |           |
|-------------------------------------|-----------|
| <b>Organic Roll Goods . . . . .</b> | <b>49</b> |
| Mirada Stitchlock                   |           |
| Must Have                           |           |
| Broken Checks                       |           |
| Connetic                            |           |



## GEOMETRIC PATTERNS

### CARPET TILES

---

|  |           |
|--|-----------|
| <b>Geometric Small</b> . . . . .         | <b>57</b> |
| Enlivened                                |           |
| Side Stripe                              |           |
| Venturesome                              |           |
| <b>Geometric Medium</b> . . . . .        | <b>63</b> |
| Insurgent                                |           |
| Riot                                     |           |
| Motivated Movement                       |           |
| <b>Geometric Large</b> . . . . .         | <b>69</b> |
| First One Up II                          |           |
| Reckless                                 |           |
| Lateral Surface                          |           |
| <b>Geometric Complimentary</b> . . . . . | <b>75</b> |
| Draft Point                              |           |
| Headstrong                               |           |
| X-Factor                                 |           |

### CARPET PLANKS

---

|  |           |
|--|-----------|
| <b>Geometric Small</b> . . . . .         | <b>81</b> |
| Chitalpa                                 |           |
| Biome                                    |           |
| Metallic Path                            |           |
| <b>Geometric Medium</b> . . . . .        | <b>87</b> |
| LineD                                    |           |
| Proficient                               |           |
| Digital Terrain                          |           |
| <b>Geometric Large</b> . . . . .         | <b>93</b> |
| SquareD                                  |           |
| Seismic Wave                             |           |
| Kinesthetic                              |           |
| <b>Geometric Complimentary</b> . . . . . | <b>99</b> |
| Hyper Earth                              |           |
| Sabbatical                               |           |
| Write Direction                          |           |

### BROADLOOM

---

|                                       |            |
|---------------------------------------|------------|
| <b>Geometric Roll Goods</b> . . . . . | <b>105</b> |
| New Basics III                        |            |
| End Result                            |            |
| Gathered Style                        |            |
| Trail Mix                             |            |



# Contents

## **COMPLIMENTARY**

### **PATTERNS . . . . . 113**

- In The Loop
- New Basics III Tile
- First Step II

### **ADHESIVES . . . . . 119**

- Nubroadlok
- Enpress
- FlexLok



# Caliber

|              |  |
|--------------|--|
| Collection   | Bending Earth                              |
| Style Name   | Caliber                                    |
| Style Number | BT282                                      |
| Product Type | Carpet Tile                                |
| Size         | 24" X 24"                                  |
| Construction | Tufted                                     |
| Installation | Monolithic, Quarter Turn, Vertical Ashlar, |



| Feature              | Description                                |
|----------------------|--|
| Backing Material     | EcoFlex Matrix                             |
| Fiber Type           | ColorStrand® SD Nylon                      |
| Dye Method           | Solution Dyed                              |
| Installation Methods | Monolithic, Quarter Turn, Vertical Ashlar, |
| Stitches per Inch    | 11 (43.31 per 10cm)                        |
| Density              | 5361                                       |
| Tufted Pile Weight   | 14.00 oz/yd2 (475 g/m2)                    |
| Surface Texture      | Level Patterned Loop                       |

## Colorways



### Pumice

Color code: 7238  
Style number: BT282



### Opal

Color code: 7559  
Style number: BT282

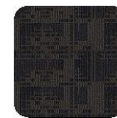

### Marble

Color code: 7568  
Style number: BT282



### Ore

Color code: 7688  
Style number: BT282



### Chert

Color code: 7728  
Style number: BT282



### Basalt

Color code: 7879  
Style number: BT282



### Shale

Color code: 7927  
Style number: BT282



### Granite

Color code: 7948  
Style number: BT282

## Performance

| Feature                          | Description                    |
|----------------------------------|--------------------------------|
| Gauge                            | 1/12 (47.00 rows per 10 cm)    |
| Foot Traffic Recommendation TARR | Severe                         |
| Flammability                     | ASTM E 648 Class 1 (Glue Down) |
| Smoke Density                    | ASTM E 662 Less than 450       |
| Static Propensity                | AATCC-134 Under 3.5 KV         |
| Soil Release Technology          | EcoSentry Soil Protection      |



## Sustainability

| Feature                         | Description  |
|---------------------------------|--|
| Beyond Carbon Neutral           | This product is 100% carbon neutral plus an additional 5% offset |
| Carbon Handprint                | -0.057 kg CO2e/ft2   |
| Embodied Carbon                 | 1.14 kg CO2e/ft2   |
| Total Recycled Content          | 48%  |
| Pre-Consumer Recycled Content   | 48%  |
| NSF 140                         | <a href="#">EcoFlex Matrix - NSF 140 Gold</a>                    |
| Indoor Air Quality              | <a href="#">GLP 1171</a>   |
| TVOC Range                      | 0.5 mg/m3 or less  |
| Red List Free                   | True   |
| Declare Label                   | Nylon Modular Carpet on EcoFlex Matrix                           |
| Mindful Materials               | Participates in Mindful Materials Library                        |
| Take Back Program               | <a href="#">ReCover Program</a>                                  |
| Health Product Declaration      | <a href="#">HPD 2.1 EcoFlex Matrix - 1000 ppm</a>                |
| Environmental Claims Validation | <a href="#">EPD EcoFlex Matrix</a>                               |
| Global Green Tag                | GreenRate Level A, LCARate Silver Plus                           |
| LEED Credit Potential           | LEED Eligible  |

## Warranties

Lifetime Limited Carpet Tile Warranty, Lifetime Limited Colorfastness to Light, 10 Year Limited Colorfastness to Atmospheric Contaminants, 10 Year Limited Stain Warranty, Lifetime Static



# Flux Play

|              |  |
|--------------|--|
| Collection   | Shape & Flow                               |
| Style Name   | Flux Play                                  |
| Style Number | BT584                                      |
| Product Type | Carpet Tile                                |
| Size         | 24" X 24"                                  |
| Construction | Tufted                                     |
| Installation | Quarter Turn, Monolithic, Vertical Ashlar, |

| Feature              | Description                                |
|----------------------|--|
| Backing Material     | Ecoflex Matrix                             |
| Fiber Type           | ColorStrand® SD Nylon                      |
| Dye Method           | Solution Dyed                              |
| Installation Methods | Quarter Turn, Monolithic, Vertical Ashlar, |
| Stitches per Inch    | 11.5 (45.28 per 10cm)                      |
| Density              | 6776                                       |
| Tufted Pile Weight   | 16.00 oz/yd2 (543 g/m2)                    |
| Surface Texture      | Level Multi-Colored Patterned Loop         |

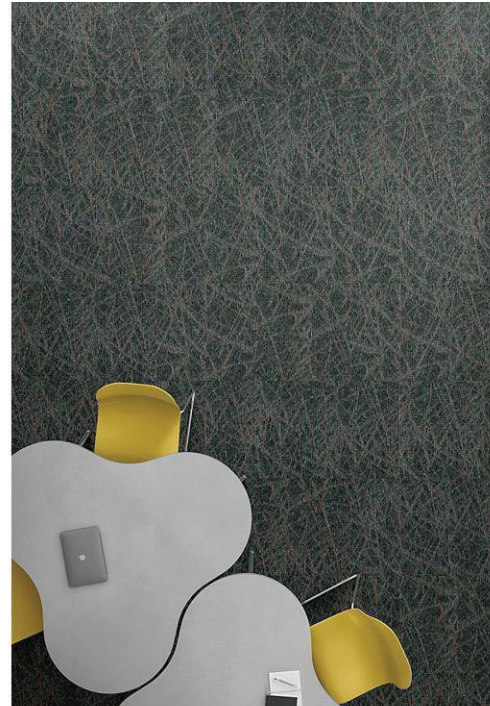

## Colorways



### Rift

Color code: 568  
Style number: BT584

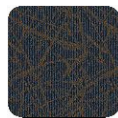

### Hydric

Color code: 569  
Style number: BT584



### Dredge

Color code: 853  
Style number: BT584



### Outfall

Color code: 924  
Style number: BT584

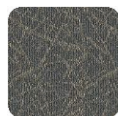

### Levi

Color code: 957  
Style number: BT584

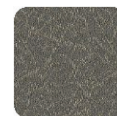

### Sediment

Color code: 958  
Style number: BT584



### Channel

Color code: 959  
Style number: BT584



### Gravel

Color code: 989  
Style number: BT584





## Performance

| Feature                          | Description                    |
|----------------------------------|--------------------------------|
| Gauge                            | 1/12 (47.00 rows per 10 cm)    |
| Stain Release Technology         | Pass                           |
| Foot Traffic Recommendation TARR | Heavy                          |
| Flammability                     | ASTM E 648 Class 1 (Glue Down) |
| Smoke Density                    | ASTM E 662 Less than 450       |
| Static Propensity                | AATCC-134 Under 3.5 KV         |
| Soil Release Technology          | EcoSentry Soil Protection      |

## Sustainability

| Feature                         | Description  |
|---------------------------------|--|
| Beyond Carbon Neutral           | This product is 100% carbon neutral plus an additional 5% offset |
| Carbon Handprint                | -0.055 kg CO2e/ft2   |
| Embodied Carbon                 | 1.1 kg CO2e/ft2  |
| Pre-Consumer Recycled Content   | 53%  |
| NSF 140                         | <a href="#">EcoFlex Matrix - NSF 140 Gold</a>                    |
| TVOC Range                      | 0.5 mg/m3 or less  |
| Red List Free                   | True   |
| Declare Label                   | Nylon Modular Carpet on EcoFlex Matrix                           |
| Mindful Materials               | Participates in Mindful Materials Library                        |
| Take Back Program               | <a href="#">ReCover Program</a>                                  |
| Health Product Declaration      | <a href="#">HPD 2.1 EcoFlex Matrix - 1000 ppm</a>                |
| Environmental Claims Validation | <a href="#">EPD EcoFlex Matrix</a>                               |
| LEED Credit Potential           | LEED Eligible  |

## Warranties

Lifetime Limited Carpet Tile Warranty, Lifetime Limited Colorfastness to Light, 10 Year Limited Colorfastness to Atmospheric Contaminants, 10 Year Limited Stain Warranty, Lifetime Static











# Filtering Form

|              |  |
|--------------|--|
| Collection   | Crossing Current                           |
| Style Name   | Filtering Form                             |
| Style Number | BT583                                      |
| Product Type | Carpet Tile                                |
| Size         | 24" X 24"                                  |
| Construction | Tufted                                     |
| Installation | Quarter Turn, Brick Ashlar, Multi-Directio |



| Feature              | Description                                |
|----------------------|--|
| Backing Material     | Ecoflex Matrix                             |
| Fiber Type           | ColorStrand® SD Nylon                      |
| Dye Method           | Solution Dyed                              |
| Installation Methods | Quarter Turn, Brick Ashlar, Multi-Director |
| Stitches per Inch    | 11.4 (44.88 per 10cm)                      |
| Density              | 5284                                       |
| Tufted Pile Weight   | 16.00 oz/yd2 (543 g/m2)                    |
| Surface Texture      | Patterned Loop                             |

## Colorways

|  |   |  |
|--|---|--|
|  <p><b>Jennings</b></p> <p>Color code: 589<br/>Style number: BT583</p> |  <p><b>Platte</b></p> <p>Color code: 898<br/>Style number: BT583</p> |  <p><b>Canning</b></p> <p>Color code: 975<br/>Style number: BT583</p> |
|  <p><b>Laurel</b></p> <p>Color code: 976<br/>Style number: BT583</p>   |  <p><b>Alder</b></p> <p>Color code: 978<br/>Style number: BT583</p>  |  <p><b>Firth</b></p> <p>Color code: 979<br/>Style number: BT583</p>   |
|  <p><b>Seneca</b></p> <p>Color code: 988<br/>Style number: BT583</p>   |  <p><b>Dakota</b></p> <p>Color code: 989<br/>Style number: BT583</p> |  |

## Performance

| Feature                          | Description                    |
|----------------------------------|--------------------------------|
| Gauge                            | 1/12 (47.00 rows per 10cm)     |
| Foot Traffic Recommendation TARR | Heavy                          |
| Flammability                     | ASTM E 648 Class 1 (Glue Down) |
| Smoke Density                    | ASTM E 662 Less than 450       |
| Static Propensity                | AATCC-134 Under 3.5 KV         |
| Soil Release Technology          | EcoSentry Soil Protection      |



## Sustainability

| Feature                         | Description  |
|---------------------------------|--|
| Beyond Carbon Neutral           | This product is 100% carbon neutral plus an additional 5% offset |
| Carbon Handprint                | -0.055 kg CO2e/ft2   |
| Embodied Carbon                 | 1.1 kg CO2e/ft2  |
| Pre-Consumer Recycled Content   | 51%  |
| NSF 140                         | <a href="#">EcoFlex Matrix - NSF 140 Gold</a>                    |
| Indoor Air Quality              | <a href="#">GLP 1171</a>   |
| TVOC Range                      | 0.5 mg/m3 or less  |
| Red List Free                   | True   |
| Declare Label                   | Nylon Modular Carpet on EcoFlex Matrix                           |
| Mindful Materials               | Participates in Mindful Materials Library                        |
| Take Back Program               | <a href="#">ReCover Program</a>                                  |
| Health Product Declaration      | <a href="#">HPD 2.1 EcoFlex Matrix - 1000 ppm</a>                |
| Environmental Claims Validation | <a href="#">EPD EcoFlex Matrix</a>                               |
| LEED Credit Potential           | LEED Eligible  |

## Warranties

Lifetime Limited Carpet Tile Warranty, Lifetime Limited Colorfastness to Light, 10 Year Colorfastness to Atmospheric Contaminants, 10 Year Stain Warranty, Limited Static



# Academic View

|              |  |
|--------------|--|
| Collection   | Art Exposure                               |
| Style Name   | Academic View                              |
| Style Number | BT433                                      |
| Product Type | Carpet Tile                                |
| Size         | 24" X 24"                                  |
| Construction | Tufted                                     |
| Installation | Quarter Turn, Vertical Ashlar, Brick Ashle |



| Feature              | Description                                |
|----------------------|--|
| Overall Thickness    | .184" (4.67 mm)                            |
| Backing Material     | EcoFlex Matrix                             |
| Fiber Type           | ColorStrand® SD Nylon                      |
| Dye Method           | Solution Dyed                              |
| Installation Methods | Quarter Turn, Vertical Ashlar, Brick Ashle |
| Stitches per Inch    | 12 (47.24 per 10cm)                        |
| Density              | 6725                                       |
| Tufted Pile Weight   | 17.00 oz/yd2 (576 g/m2)                    |
| Surface Texture      | Textured Patterned Multi-Colored Loop      |

## Colorways



### Cadet

Color code: 569  
Style number: BT433



### Fallow

Color code: 853  
Style number: BT433

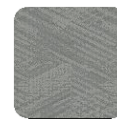

### Platinum

Color code: 924  
Style number: BT433



### Ecru

Color code: 958  
Style number: BT433



### Slate

Color code: 959  
Style number: BT433

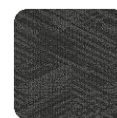

### Charcoal

Color code: 989  
Style number: BT433

## Performance

| Feature                          | Description                    |
|----------------------------------|--------------------------------|
| Gauge                            | 1/12 (47.00 rows per 10 cm)    |
| Foot Traffic Recommendation TARR | Heavy                          |
| Flammability                     | ASTM E 648 Class 1 (Glue Down) |
| Smoke Density                    | ASTM E 662 Less than 450       |
| Static Propensity                | AATCC-134 Under 3.5 KV         |
| Soil Release Technology          | EcoSentry Soil Protection      |



## Sustainability

| Feature                         | Description  |
|---------------------------------|--|
| Beyond Carbon Neutral           | This product is 100% carbon neutral plus an additional 5% offset |
| Carbon Handprint                | -0.057 kg CO2e/ft2   |
| Embodied Carbon                 | 1.14 kg CO2e/ft2   |
| Total Recycled Content          | 52%  |
| Pre-Consumer Recycled Content   | 52%  |
| NSF 140                         | <a href="#">EcoFlex Matrix - NSF 140 Gold</a>                    |
| Indoor Air Quality              | <a href="#">GLP 1171</a>   |
| TVOC Range                      | 0.5 mg/m3 or less  |
| Red List Free                   | True   |
| Declare Label                   | Nylon Modular Carpet on EcoFlex Matrix                           |
| Mindful Materials               | Participates in Mindful Materials Library                        |
| Take Back Program               | <a href="#">ReCover Program</a>                                  |
| Health Product Declaration      | <a href="#">HPD 2.1 EcoFlex Matrix - 1000 ppm</a>                |
| Environmental Claims Validation | <a href="#">EPD EcoFlex Matrix</a>                               |
| LEED Credit Potential           | LEED Eligible  |

## Warranties

Lifetime Limited Carpet Tile Warranty, Lifetime Limited Colorfastness to Light, 10 Year Colorfastness to Atmospheric Contaminants, 10 Year Stain Warranty, Lifetime Static



# Refined Pass

|              |   |
|--------------|---|
| Collection   | Crossing Current                              |
| Style Name   | Refined Pass                                  |
| Style Number | BT582   |
| Product Type | Carpet Tile                                   |
| Size         | 24" X 24"                                     |
| Construction | Tufted  |
| Installation | Quarter Turn, Brick Ashlar, Multi-Directional |

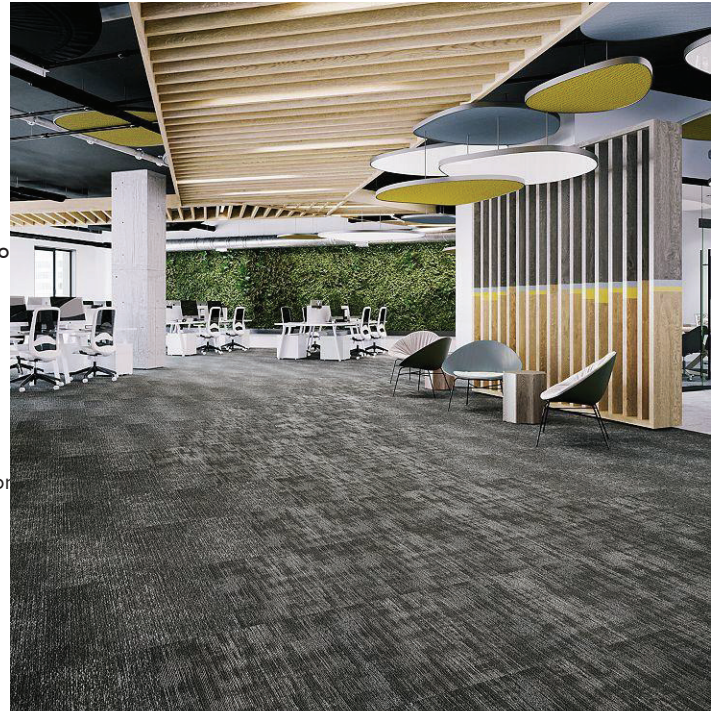

| Feature              | Description                                      |
|----------------------|--|
| Backing Material     | Ecoflex Matrix                                   |
| Fiber Type           | ColorStrand® SD Nylon                            |
| Dye Method           | Solution Dyed                                    |
| Installation Methods | Quarter Turn, Brick Ashlar, Multi-Directional    |
| Stitches per Inch    | 11.4 (44.88 per 10cm)                            |
| Density              | 6063   |
| Tufted Pile Weight   | 16.00 oz/yd <sup>2</sup> (543 g/m <sup>2</sup> ) |
| Surface Texture      | Patterned Loop                                   |

## Colorways



### Jennings

Color code: 589  
Style number: BT582



### Platte

Color code: 898  
Style number: BT582



### Canning

Color code: 975  
Style number: BT582



### Laurel

Color code: 976  
Style number: BT582



### Alder

Color code: 978  
Style number: BT582



### Firth

Color code: 979  
Style number: BT582



### Seneca

Color code: 988  
Style number: BT582



### Dakota

Color code: 989  
Style number: BT582

## Performance

| Feature                          | Description                    |
|----------------------------------|--------------------------------|
| Gauge                            | 1/12 (47.00 rows per 10cm)     |
| Foot Traffic Recommendation TARR | Heavy                          |
| Flammability                     | ASTM E 648 Class 1 (Glue Down) |
| Smoke Density                    | ASTM E 662 Less than 450       |
| Static Propensity                | AATCC-134 Under 3.5 KV         |
| Soil Release Technology          | EcoSentry Soil Protection      |



## Sustainability

| Feature                         | Description  |
|---------------------------------|--|
| Beyond Carbon Neutral           | This product is 100% carbon neutral plus an additional 5% offset |
| Carbon Handprint                | -0.055 kg CO2e/ft2   |
| Embodied Carbon                 | 1.1 kg CO2e/ft2  |
| Pre-Consumer Recycled Content   | 51%  |
| NSF 140                         | <a href="#">EcoFlex Matrix - NSF 140 Gold</a>                    |
| Indoor Air Quality              | <a href="#">GLP 1171</a>   |
| TVOC Range                      | 0.5 mg/m3 or less  |
| Red List Free                   | True   |
| Declare Label                   | Nylon Modular Carpet on EcoFlex Matrix                           |
| Mindful Materials               | Participates in Mindful Materials Library                        |
| Take Back Program               | <a href="#">ReCover Program</a>                                  |
| Health Product Declaration      | <a href="#">HPD 2.1 EcoFlex Matrix - 1000 ppm</a>                |
| Environmental Claims Validation | <a href="#">EPD EcoFlex Matrix</a>                               |
| LEED Credit Potential           | LEED Eligible  |

## Warranties

Lifetime Limited Carpet Tile Warranty, Lifetime Limited Colorfastness to Light, 10 Year Colorfastness to Atmospheric Contaminants, 10 Year Stain Warranty, Limited Static



# Framed Structure

|              |  |
|--------------|--|
| Collection   | Sketch Effect                              |
| Style Name   | Framed Structure                           |
| Style Number | BT436                                      |
| Product Type | Carpet Tile                                |
| Size         | 24" X 24"                                  |
| Construction | Tufted                                     |
| Installation | Quarter Turn, Monolithic, Vertical Ashlar, |



| Feature              | Description                                |
|----------------------|--|
| Backing Material     | EcoFlex Matrix, EcoFlex AIR                |
| Fiber Type           | ColorStrand® SD Nylon                      |
| Dye Method           | Solution Dyed                              |
| Installation Methods | Quarter Turn, Monolithic, Vertical Ashlar, |
| Stitches per Inch    | 11 (43.31 per 10cm)                        |
| Density              | 6585                                       |
| Tufted Pile Weight   | 15.00 oz/yd2 (509 g/m2)                    |
| Surface Texture      | Textured Patterned Loop                    |

## Colorways



### Navy Gray

Color code: 593  
Style number: BT436



### Light Elm

Color code: 929  
Style number: BT436



### Steel

Color code: 937  
Style number: BT436



### Brown Oak

Color code: 948  
Style number: BT436



### Pencil Lead

Color code: 979  
Style number: BT436



### Charcoal

Color code: 989  
Style number: BT436

## Performance

| Feature                          | Description                    |
|----------------------------------|--------------------------------|
| Gauge                            | 1/12 (47.00 rows per 10 cm)    |
| Foot Traffic Recommendation TARR | Heavy                          |
| Flammability                     | ASTM E 648 Class 1 (Glue Down) |
| Smoke Density                    | ASTM E 662 Less than 450       |
| Static Propensity                | AATCC-134 Under 3.5 KV         |
| Soil Release Technology          | EcoSentry Soil Protection      |





## Sustainability

| Feature                         | Description  |
|---------------------------------|--|
| Beyond Carbon Neutral           | This product is 100% carbon neutral plus an additional 5% offset |
| Carbon Handprint                | -0.053 kg CO2e/ft2   |
| Embodied Carbon                 | 1.06 kg CO2e/ft2   |
| Total Recycled Content          | 53%  |
| Pre-Consumer Recycled Content   | 53%  |
| NSF 140                         | <a href="#">EcoFlex Matrix - NSF 140 Gold</a>                    |
| Indoor Air Quality              | <a href="#">GLP 1171</a>   |
| TVOC Range                      | 0.5 mg/m3 or less  |
| Red List Free                   | True   |
| Declare Label                   | Nylon Modular Carpet on EcoFlex Matrix                           |
| Mindful Materials               | Participates in Mindful Materials Library                        |
| Take Back Program               | <a href="#">ReCover Program</a>                                  |
| Health Product Declaration      | <a href="#">HPD 2.1 EcoFlex Matrix - 1000 ppm</a>                |
| Environmental Claims Validation | <a href="#">EPD EcoFlex Matrix</a>                               |
| LEED Credit Potential           | LEED Eligible  |

## Warranties

Lifetime Limited Carpet Tile Warranty, Lifetime Limited Colorfastness to Light, 10 Year Limited Colorfastness to Atmospheric Contaminants, 10 Year Stain Warranty, Lifetime Static



# Flux Foundation

|              |  |
|--------------|--|
| Collection   | Shape & Flow                               |
| Style Name   | Flux Foundation                            |
| Style Number | BT585                                      |
| Product Type | Carpet Tile                                |
| Size         | 24" X 24"                                  |
| Construction | Tufted                                     |
| Installation | Quarter Turn, Monolithic, Vertical Ashlar, |



| Feature              | Description                                |
|----------------------|--|
| Backing Material     | EcoFlex Matrix                             |
| Fiber Type           | ColorStrand® SD Nylon                      |
| Dye Method           | Solution Dyed                              |
| Installation Methods | Quarter Turn, Monolithic, Vertical Ashlar, |
| Stitches per Inch    | 10.5 (41.34 per 10cm)                      |
| Density              | 6193                                       |
| Tufted Pile Weight   | 16.00 oz/yd2 (543 g/m2)                    |
| Surface Texture      | Level Multi-Colored Patterned Loop         |

## Colorways



### Rift

Color code: 568  
Style number: BT585



### Hydric

Color code: 569  
Style number: BT585



### Dredge

Color code: 853  
Style number: BT585



### Outfall

Color code: 924  
Style number: BT585



### Levi

Color code: 957  
Style number: BT585



### Sediment

Color code: 958  
Style number: BT585



### Channel

Color code: 959  
Style number: BT585



### Gravel

Color code: 989  
Style number: BT585



## Performance

| Feature                          | Description                    |
|----------------------------------|--------------------------------|
| Gauge                            | 1/12 (47.00 rows per 10 cm)    |
| Stain Release Technology         | Pass                           |
| Foot Traffic Recommendation TARR | Heavy                          |
| Flammability                     | ASTM E 648 Class 1 (Glue Down) |
| Smoke Density                    | ASTM E 662 Less than 450       |
| Static Propensity                | AATCC-134 Under 3.5 KV         |
| Soil Release Technology          | EcoSentry Soil Protection      |

## Sustainability

| Feature                         | Description  |
|---------------------------------|--|
| Beyond Carbon Neutral           | This product is 100% carbon neutral plus an additional 5% offset |
| Carbon Handprint                | -0.055 kg CO2e/ft2   |
| Embodied Carbon                 | 1.1 kg CO2e/ft2  |
| Pre-Consumer Recycled Content   | 53%  |
| NSF 140                         | <a href="#">EcoFlex Matrix - NSF 140 Gold</a>                    |
| TVOC Range                      | 0.5 mg/m3 or less  |
| Red List Free                   | True   |
| Declare Label                   | Nylon Modular Carpet on EcoFlex Matrix                           |
| Mindful Materials               | Participates in Mindful Materials Library                        |
| Take Back Program               | <a href="#">ReCover Program</a>                                  |
| Health Product Declaration      | <a href="#">HPD 2.1 EcoFlex Matrix - 1000 ppm</a>                |
| Environmental Claims Validation | <a href="#">EPD EcoFlex Matrix</a>                               |
| LEED Credit Potential           | LEED Eligible  |

## Warranties

Lifetime Limited Carpet Tile Warranty, Lifetime Limited Colorfastness to Light, 10 Year Limited Colorfastness to Atmospheric Contaminants, 10 Year Stain Warranty, Lifetime Static









# Shaded Lines

|              |                               |
|--------------|-------------------------------|
| Collection   | Sketch Effect                 |
| Style Name   | Shaded Lines                  |
| Style Number | BT437                         |
| Product Type | Carpet Tile                   |
| Size         | 24" X 24"                     |
| Construction | Tufted                        |
| Installation | Vertical Ashlar, Quarter Turn |



| Feature              | Description                   |
|----------------------|-------------------------------|
| Backing Material     | EcoFlex Matrix, EcoFlex AIR   |
| Fiber Type           | ColorStrand® SD Nylon         |
| Dye Method           | Solution Dyed                 |
| Installation Methods | Vertical Ashlar, Quarter Turn |
| Stitches per Inch    | 11 (43.31 per 10cm)           |
| Density              | 6000                          |
| Tufted Pile Weight   | 15.00 oz/yd2 (509 g/m2)       |
| Surface Texture      | Textured Patterned Loop       |

## Colorways

|   |  |   |
|---|--|---|
|  <p><b>Navy Gray</b></p> <p>Color code: 593<br/>Style number: BT437</p> |  <p><b>Light Elm</b></p> <p>Color code: 929<br/>Style number: BT437</p>   |  <p><b>Steel</b></p> <p>Color code: 937<br/>Style number: BT437</p>    |
|  <p><b>Brown Oak</b></p> <p>Color code: 948<br/>Style number: BT437</p> |  <p><b>Pencil Lead</b></p> <p>Color code: 979<br/>Style number: BT437</p> |  <p><b>Charcoal</b></p> <p>Color code: 989<br/>Style number: BT437</p> |

## Performance

| Feature                          | Description                    |
|----------------------------------|--------------------------------|
| Gauge                            | 1/12 (47.00 rows per 10 cm)    |
| Foot Traffic Recommendation TARR | Heavy                          |
| Flammability                     | ASTM E 648 Class 1 (Glue Down) |
| Smoke Density                    | ASTM E 662 Less than 450       |
| Static Propensity                | AATCC-134 Under 3.5 KV         |
| Soil Release Technology          | EcoSentry Soil Protection      |



## Sustainability

| Feature                         | Description  |
|---------------------------------|--|
| Beyond Carbon Neutral           | This product is 100% carbon neutral plus an additional 5% offset |
| Carbon Handprint                | -0.053 kg CO2e/ft2   |
| Embodied Carbon                 | 1.06 kg CO2e/ft2   |
| Total Recycled Content          | 53%  |
| Pre-Consumer Recycled Content   | 53%  |
| NSF 140                         | <a href="#">EcoFlex Matrix - NSF 140 Gold</a>                    |
| Indoor Air Quality              | <a href="#">GLP 1171</a>   |
| TVOC Range                      | 0.5 mg/m3 or less  |
| Red List Free                   | True   |
| Declare Label                   | Nylon Modular Carpet on EcoFlex Matrix                           |
| Mindful Materials               | Participates in Mindful Materials Library                        |
| Take Back Program               | <a href="#">ReCover Program</a>                                  |
| Health Product Declaration      | <a href="#">HPD 2.1 EcoFlex Matrix - 1000 ppm</a>                |
| Environmental Claims Validation | <a href="#">EPD EcoFlex Matrix</a>                               |
| LEED Credit Potential           | LEED Eligible  |

## Warranties

Lifetime Limited Carpet Tile Warranty, Lifetime Limited Colorfastness to Light, 10 Year Limited Colorfastness to Atmospheric Contaminants, 10 Year Stain Warranty, Lifetime Static



# Rise Up

|              |  |
|--------------|--|
| Collection   | Learn and Live                             |
| Style Name   | Rise Up                                    |
| Style Number | GT420                                      |
| Product Type | Carpet Tile                                |
| Size         | 24" X 24"                                  |
| Construction | Tufted                                     |
| Installation | Quarter Turn, Vertical Ashlar, Brick Ashla |



| Feature              | Description                                |
|----------------------|--|
| Backing Material     | EcoFlex ONE                                |
| Fiber Type           | Duracolor® Tricor Premium Nylon            |
| Dye Method           | Solution Dyed                              |
| Installation Methods | Quarter Turn, Vertical Ashlar, Brick Ashla |
| Stitches per Inch    | 12.4 (48.82 per 10cm)                      |
| Density              | 5884                                       |
| Tufted Pile Weight   | 17.00 oz/yd2 (576 g/m2)                    |
| Surface Texture      | Textured Patterned Loop                    |

## Colorways

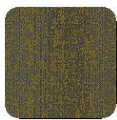

### Highland

Color code: 149  
Style number: GT420



### Westwood

Color code: 265  
Style number: GT420



### Liberty

Color code: 368  
Style number: GT420



### Roan

Color code: 369  
Style number: GT420



### Washington

Color code: 459  
Style number: GT420



### Lincoln

Color code: 559  
Style number: GT420



### Northview

Color code: 655  
Style number: GT420



### Douglas

Color code: 968  
Style number: GT420



## Performance

| Feature                          | Description                    |
|----------------------------------|--------------------------------|
| Gauge                            | 1/12 (47.00 rows per 10 cm)    |
| Stain Release Technology         | Pass                           |
| Foot Traffic Recommendation TARR | Severe                         |
| Flammability                     | ASTM E 648 Class 1 (Glue Down) |
| Smoke Density                    | ASTM E 662 Less than 450       |
| Static Propensity                | AATCC-134 Under 3.5 KV         |
| Soil Release Technology          | EcoSentry Soil Protection      |

## Sustainability

| Feature                         | Description  |
|---------------------------------|--|
| Beyond Carbon Neutral           | This product is 100% carbon neutral plus an additional 5% offset |
| Carbon Handprint                | -0.06 kg CO2e/ft2  |
| Embodied Carbon                 | 1.2 kg CO2e/ft2  |
| Total Recycled Content          | 59%  |
| Pre-Consumer Recycled Content   | 59%  |
| NSF 140                         | EcoFlex ONE - NSF 140 Gold                                       |
| Indoor Air Quality              | <a href="#">GLP 1171</a>   |
| TVOC Range                      | 0.5 mg/m3 or less  |
| Red List Free                   | True   |
| Mindful Materials               | Participates in Mindful Materials Library                        |
| Take Back Program               | <a href="#">ReCover Program</a>                                  |
| Health Product Declaration      | HPD 2.1 EcoFlex ONE Gold - 1000 ppm                              |
| Environmental Claims Validation | EPD EcoFlex ONE  |
| LEED Credit Potential           | LEED Eligible  |

## Warranties

Lifetime Limited Carpet Tile Warranty, Lifetime Duracolor Stain Warranty, Lifetime Static



# Statement Stone

|              |  |
|--------------|--|
| Collection   | Iconic Earth                               |
| Style Name   | Statement Stone                            |
| Style Number | BT390                                      |
| Product Type | Carpet Tile                                |
| Size         | 24" X 24"                                  |
| Construction | Tufted                                     |
| Installation | Quarter Turn, Brick Ashlar, Vertical Ashla |

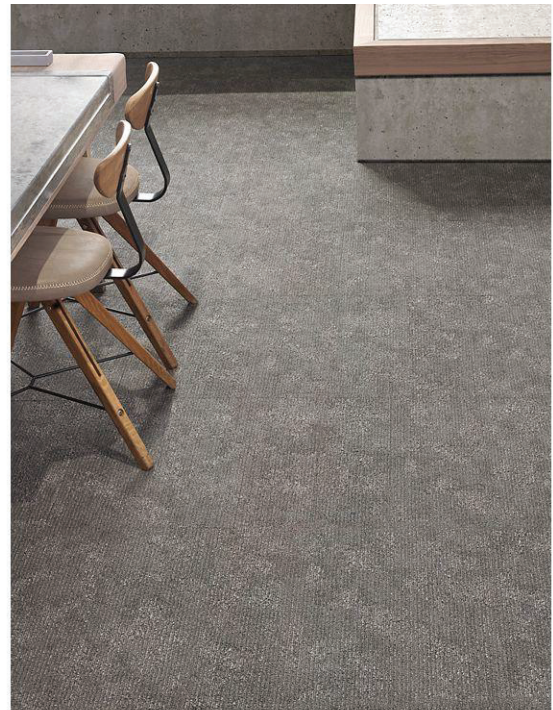

| Feature              | Description                                |
|----------------------|--|
| Backing Material     | EcoFlex NXT                                |
| Fiber Type           | ColorStrand® SD Nylon                      |
| Dye Method           | Solution Dyed                              |
| Installation Methods | Quarter Turn, Brick Ashlar, Vertical Ashla |
| Stitches per Inch    | 11.2 (44.09 per 10cm)                      |
| Density              | 8576                                       |
| Tufted Pile Weight   | 16.20 oz/yd2 (549 g/m2)                    |
| Surface Texture      | Textured Patterned Loop                    |

## Colorways



### Rugged Range

Color code: 152  
Style number: BT390



### Classic Ridge

Color code: 358  
Style number: BT390



### Perfect Paths

Color code: 751  
Style number: BT390



### Downing Stone

Color code: 859  
Style number: BT390



### Canyon Clay

Color code: 862  
Style number: BT390



### Wild Terrain

Color code: 883  
Style number: BT390



### Solid Ground

Color code: 955  
Style number: BT390



### Clean Slate

Color code: 983  
Style number: BT390



### Daring Drift

Color code: 999  
Style number: BT390

## Performance

| Feature                          | Description                    |
|----------------------------------|--------------------------------|
| Gauge                            | 1/12 (47.00 rows per 10 cm)    |
| Foot Traffic Recommendation TARR | Heavy                          |
| Flammability                     | ASTM E 648 Class 1 (Glue Down) |
| Smoke Density                    | ASTM E 662 Less than 450       |
| Static Propensity                | AATCC-134 Under 3.5 KV         |
| Soil Release Technology          | EcoSentry Soil Protection      |





## Sustainability

| Feature                         | Description  |
|---------------------------------|--|
| Beyond Carbon Neutral           | This product is 100% carbon neutral plus an additional 5% offset |
| Carbon Handprint                | -0.058 kg CO2e/ft2   |
| Embodied Carbon                 | 1.16 kg CO2e/ft2   |
| Total Recycled Content          | 48%  |
| Pre-Consumer Recycled Content   | 48%  |
| NSF 140                         | <a href="#">EcoFlex NXT - NSF 140 Gold</a>                       |
| Indoor Air Quality              | <a href="#">GLP 1171</a>   |
| TVOC Range                      | 0.5 mg/m3 or less  |
| Red List Free                   | True   |
| Declare Label                   | Nylon Modular Carpet on EcoFlex NXT                              |
| Mindful Materials               | Participates in Mindful Materials Library                        |
| Take Back Program               | <a href="#">ReCover Program</a>                                  |
| Health Product Declaration      | <a href="#">HPD 2.1 EcoFlex NXT Gold - 1000 ppm</a>              |
| Environmental Claims Validation | <a href="#">EPD EcoFlex NXT</a>                                  |
| Global Green Tag                | GreenRate Level A, LCARate Silver Plus                           |
| LEED Credit Potential           | LEED Eligible  |

## Warranties

Lifetime Limited Carpet Tile Warranty, Lifetime Limited Colorfastness to Light, 10 Year Limited Colorfastness to Atmospheric Contaminants, 10 Year Limited Stain Warranty



# Datum

|              |  |
|--------------|--|
| Collection   | Bending Earth                              |
| Style Name   | Datum                                      |
| Style Number | BT284                                      |
| Product Type | Carpet Tile                                |
| Size         | 24" X 24"                                  |
| Construction | Tufted                                     |
| Installation | Monolithic, Quarter Turn, Vertical Ashlar, |



| Feature              | Description                                |
|----------------------|--|
| Backing Material     | EcoFlex Matrix                             |
| Fiber Type           | ColorStrand® SD Nylon                      |
| Dye Method           | Solution Dyed                              |
| Installation Methods | Monolithic, Quarter Turn, Vertical Ashlar, |
| Stitches per Inch    | 11 (43.31 per 10cm)                        |
| Density              | 5040                                       |
| Tufted Pile Weight   | 14.40 oz/yd2 (488 g/m2)                    |
| Surface Texture      | Level Patterned Loop                       |

## Colorways



### Pumice

Color code: 7238  
Style number: BT284



### Opal

Color code: 7559  
Style number: BT284



### Marble

Color code: 7568  
Style number: BT284



### Ore

Color code: 7688  
Style number: BT284



### Chert

Color code: 7728  
Style number: BT284



### Basalt

Color code: 7879  
Style number: BT284



### Shale

Color code: 7927  
Style number: BT284



### Granite

Color code: 7948  
Style number: BT284



## Performance

| Feature                          | Description                    |
|----------------------------------|--------------------------------|
| Gauge                            | 1/12 (49.00 rows per 10 cm)    |
| Stain Release Technology         | Pass                           |
| Foot Traffic Recommendation TARR | Heavy                          |
| Flammability                     | ASTM E 648 Class 1 (Glue Down) |
| Smoke Density                    | ASTM E 662 Less than 450       |
| Static Propensity                | AATCC-134 Under 3.5 KV         |
| Soil Release Technology          | EcoSentry Soil Protection      |

## Sustainability

| Feature                         | Description  |
|---------------------------------|--|
| Beyond Carbon Neutral           | This product is 100% carbon neutral plus an additional 5% offset |
| Carbon Handprint                | -0.057 kg CO2e/ft2   |
| Embodied Carbon                 | 1.14 kg CO2e/ft2   |
| Total Recycled Content          | 48%  |
| Pre-Consumer Recycled Content   | 48%  |
| NSF 140                         | <a href="#">EcoFlex Matrix - NSF 140 Gold</a>                    |
| Indoor Air Quality              | <a href="#">GLP 1171</a>   |
| TVOC Range                      | 0.5 mg/m3 or less  |
| Red List Free                   | True   |
| Declare Label                   | Nylon Modular Carpet on EcoFlex Matrix                           |
| Mindful Materials               | Participates in Mindful Materials Library                        |
| Take Back Program               | <a href="#">ReCover Program</a>                                  |
| Health Product Declaration      | <a href="#">HPD 2.1 EcoFlex Matrix - 1000 ppm</a>                |
| Environmental Claims Validation | <a href="#">EPD EcoFlex Matrix</a>                               |
| Global Green Tag                | GreenRate Level A, LCARate Silver Plus                           |
| LEED Credit Potential           | LEED Eligible  |

## Warranties

Lifetime Limited Carpet Tile Warranty, Lifetime Limited Colorfastness to Light, 10 Year Limited Colorfastness to Atmospheric Contaminants, 10 Year Limited Stain Warranty, Lifetime Static



# Sector

|              |  |
|--------------|--|
| Collection   | Bending Earth                              |
| Style Name   | Sector                                     |
| Style Number | BT285                                      |
| Product Type | Carpet Tile                                |
| Size         | 24" X 24"                                  |
| Construction | Tufted                                     |
| Installation | Monolithic, Vertical Ashlar, Quarter Turn, |



| Feature              | Description                                |
|----------------------|--|
| Backing Material     | EcoFlex Matrix                             |
| Fiber Type           | ColorStrand® SD Nylon                      |
| Dye Method           | Solution Dyed                              |
| Installation Methods | Monolithic, Vertical Ashlar, Quarter Turn, |
| Stitches per Inch    | 11 (43.31 per 10cm)                        |
| Density              | 5929                                       |
| Tufted Pile Weight   | 17.00 oz/yd2 (576 g/m2)                    |
| Surface Texture      | Level Patterned Loop                       |

## Colorways



### Pumice

Color code: 7238  
Style number: BT285



### Opal

Color code: 7559  
Style number: BT285



### Marble

Color code: 7568  
Style number: BT285



### Ore

Color code: 7688  
Style number: BT285



### Chert

Color code: 7728  
Style number: BT285



### Basalt

Color code: 7879  
Style number: BT285



### Shale

Color code: 7927  
Style number: BT285



### Granite

Color code: 7948  
Style number: BT285



## Performance

| Feature                          | Description                    |
|----------------------------------|--------------------------------|
| Gauge                            | 1/12 (49.00 rows per 10 cm)    |
| Foot Traffic Recommendation TARR | Heavy                          |
| Flammability                     | ASTM E 648 Class 1 (Glue Down) |
| Smoke Density                    | ASTM E 662 Less than 450       |
| Static Propensity                | AATCC-134 Under 3.5 KV         |
| Soil Release Technology          | EcoSentry Soil Protection      |

## Sustainability

| Feature                         | Description  |
|---------------------------------|--|
| Beyond Carbon Neutral           | This product is 100% carbon neutral plus an additional 5% offset |
| Carbon Handprint                | -0.057 kg CO2e/ft2   |
| Embodied Carbon                 | 1.14 kg CO2e/ft2   |
| Total Recycled Content          | 48%  |
| Pre-Consumer Recycled Content   | 48%  |
| NSF 140                         | <a href="#">EcoFlex Matrix - NSF 140 Gold</a>                    |
| Indoor Air Quality              | <a href="#">GLP 1171</a>   |
| TVOC Range                      | 0.5 mg/m3 or less  |
| Red List Free                   | True   |
| Declare Label                   | Nylon Modular Carpet on EcoFlex Matrix                           |
| Mindful Materials               | Participates in Mindful Materials Library                        |
| Take Back Program               | <a href="#">ReCover Program</a>                                  |
| Health Product Declaration      | <a href="#">HPD 2.1 EcoFlex Matrix - 1000 ppm</a>                |
| Environmental Claims Validation | <a href="#">EPD EcoFlex Matrix</a>                               |
| Global Green Tag                | GreenRate Level A, LCARate Silver Plus                           |
| LEED Credit Potential           | LEED Eligible  |

## Warranties

Lifetime Limited Carpet Tile Warranty, Lifetime Limited Colorfastness to Light, 10 Year Limited Colorfastness to Atmospheric Contaminants, 10 Year Limited Stain Warranty, Lifetime Static



# Drifted Ground

|              |   |
|--------------|---|
| Collection   | Iconic Earth                                    |
| Style Name   | Drifted Ground                                  |
| Style Number | BT389   |
| Product Type | Carpet Tile                                     |
| Size         | 12" X 36"                                       |
| Construction | Tufted  |
| Installation | Monolithic, Half Lap, Brick Ashlar, Basketweave |



| Feature              | Description                                     |
|----------------------|---|
| Backing Material     | EcoFlex NXT                                     |
| Fiber Type           | ColorStrand® SD Nylon                           |
| Dye Method           | Piece Dyed                                      |
| Installation Methods | Monolithic, Half Lap, Brick Ashlar, Basketweave |
| Stitches per Inch    | 11 (43.31 per 10cm)                             |
| Density              | 4143  |
| Tufted Pile Weight   | 16.20 oz/yd2 (549 g/m2)                         |
| Surface Texture      | Textured Patterned Loop                         |

## Colorways



### Rugged Range

Color code: 152  
Style number: BT389



### Classic Ridge

Color code: 358  
Style number: BT389



### Perfect Paths

Color code: 751  
Style number: BT389



### Downing Stone

Color code: 859  
Style number: BT389



### Canyon Clay

Color code: 862  
Style number: BT389



### Wild Terrain

Color code: 883  
Style number: BT389



### Solid Ground

Color code: 955  
Style number: BT389



### Clean Slate

Color code: 983  
Style number: BT389



### Daring Drift

Color code: 999  
Style number: BT389



## Performance

| Feature                          | Description                    |
|----------------------------------|--------------------------------|
| Gauge                            | 1/12 (47.00 rows per 10 cm)    |
| Foot Traffic Recommendation TARR | Heavy                          |
| Flammability                     | ASTM E 648 Class 1 (Glue Down) |
| Smoke Density                    | ASTM E 662 Less than 450       |
| Static Propensity                | AATCC-134 Under 3.5 KV         |
| Soil Release Technology          | EcoSentry Soil Protection      |

## Sustainability

| Feature                         | Description  |
|---------------------------------|--|
| Beyond Carbon Neutral           | This product is 100% carbon neutral plus an additional 5% offset |
| Carbon Handprint                | -0.058 kg CO2e/ft2   |
| Embodied Carbon                 | 1.16 kg CO2e/ft2   |
| Total Recycled Content          | 46%  |
| Pre-Consumer Recycled Content   | 40%  |
| NSF 140                         | <a href="#">EcoFlex NXT - NSF 140 Gold</a>                       |
| Indoor Air Quality              | <a href="#">GLP 1171</a>   |
| TVOC Range                      | 0.5 mg/m3 or less  |
| Red List Free                   | True   |
| Declare Label                   | Nylon Modular Carpet on EcoFlex NXT                              |
| Mindful Materials               | Participates in Mindful Materials Library                        |
| Take Back Program               | <a href="#">ReCover Program</a>                                  |
| Health Product Declaration      | <a href="#">HPD 2.1 EcoFlex NXT Gold - 1000 ppm</a>              |
| Environmental Claims Validation | <a href="#">EPD EcoFlex NXT</a>                                  |
| Global Green Tag                | GreenRate Level A, LCARate Silver Plus                           |
| LEED Credit Potential           | LEED Eligible  |

## Warranties

Lifetime Limited Carpet Tile Warranty, Lifetime Limited Colorfastness to Light, 10 Year Limited Colorfastness to Atmospheric Contaminants, 10 Year Limited Stain Warranty, Lifetime Static



# Shifted Focus

|              |  |
|--------------|--|
| Collection   | Optic Reset                              |
| Style Name   | Shifted Focus                            |
| Style Number | GT448                                    |
| Product Type | Carpet Tile                              |
| Size         | 12" X 36"                                |
| Construction | Tufted                                   |
| Installation | Brick Ashlar, Random, Half Lap, Plank Ha |



| Feature              | Description                              |
|----------------------|--|
| Overall Thickness    | .254" (6.45 mm)                          |
| Backing Material     | EcoFlex NXT                              |
| Fiber Type           | Duracolor® Tricor Premium Nylon          |
| Dye Method           | Solution Dyed                            |
| Installation Methods | Brick Ashlar, Random, Half Lap, Plank Ha |
| Stitches per Inch    | 12.4 (48.82 per 10cm)                    |
| Density              | 6056                                     |
| Tufted Pile Weight   | 18.00 oz/yd2 (610 g/m2)                  |
| Surface Texture      | Textured Patterned Multi-Colored Loop    |

## Colorways



### Fresco

Color code: 282  
Style number: GT448



### Indigo

Color code: 585  
Style number: GT448



### Verdigris

Color code: 696  
Style number: GT448



### Nuance

Color code: 868  
Style number: GT448



### Ferro

Color code: 957  
Style number: GT448



### Moonlit

Color code: 959  
Style number: GT448



### Silhouette

Color code: 979  
Style number: GT448



### Cinematic

Color code: 987  
Style number: GT448



### Undertone

Color code: 988  
Style number: GT448





## Performance

| Feature                          | Description                    |
|----------------------------------|--------------------------------|
| Gauge                            | 1/12 (47.00 rows per 10 cm)    |
| Stain Release Technology         | Pass                           |
| Foot Traffic Recommendation TARR | Heavy                          |
| Flammability                     | ASTM E 648 Class 1 (Glue Down) |
| Smoke Density                    | ASTM E 662 Less than 450       |
| Static Propensity                | AATCC-134 Under 3.5 KV         |
| Soil Release Technology          | EcoSentry Soil Treatment       |

## Sustainability

| Feature                         | Description  |
|---------------------------------|--|
| Beyond Carbon Neutral           | This product is 100% carbon neutral plus an additional 5% offset |
| Carbon Handprint                | -0.062 kg CO2e/ft2   |
| Embodied Carbon                 | 1.24 kg CO2e/ft2   |
| Total Recycled Content          | 57%  |
| Pre-Consumer Recycled Content   | 57%  |
| NSF 140                         | <a href="#">EcoFlex NXT - NSF 140 Gold</a>                       |
| Indoor Air Quality              | <a href="#">GLP 1171</a>   |
| TVOC Range                      | 0.5 mg/m3 or less  |
| Red List Free                   | True   |
| Declare Label                   | Nylon Modular Carpet on EcoFlex NXT                              |
| Mindful Materials               | Participates in Mindful Materials Library                        |
| Take Back Program               | <a href="#">ReCover Program</a>                                  |
| Health Product Declaration      | <a href="#">HPD 2.1 EcoFlex NXT Gold - 1000 ppm</a>              |
| Environmental Claims Validation | <a href="#">EPD EcoFlex NXT</a>                                  |
| Global Green Tag                | GreenRate Level A, LCARate Silver Plus                           |
| LEED Credit Potential           | LEED Eligible  |

## Warranties

Lifetime Limited Carpet Tile Warranty, Lifetime Limited Duracolor Stain Warranty, Lifetime Static



# Unexpected Detail

|              |   |
|--------------|---|
| Collection   | Timeless Tailored                               |
| Style Name   | Unexpected Detail                               |
| Style Number | GT468   |
| Product Type | Carpet Tile                                     |
| Size         | 12" X 36"                                       |
| Construction | Tufted  |
| Installation | Monolithic, Half Lap, Brick Ashlar, Basketweave |

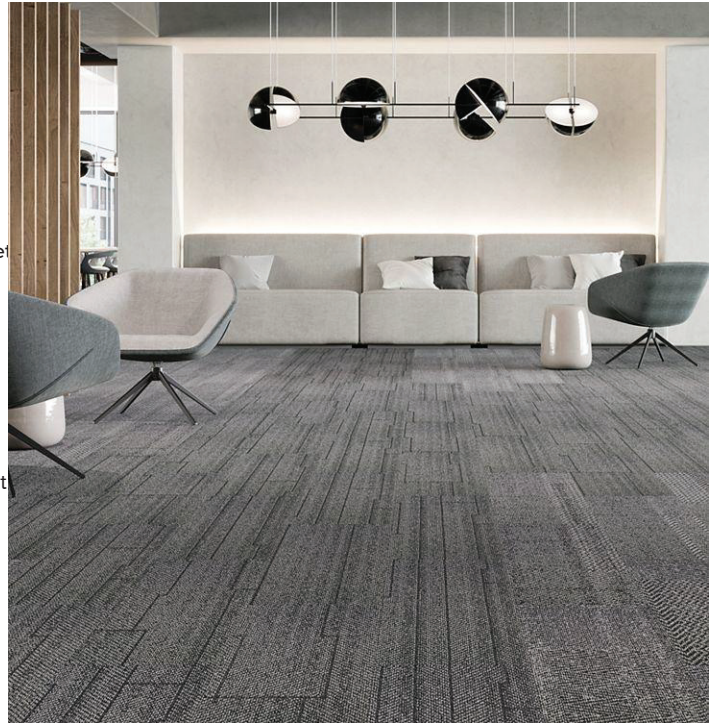

| Feature              | Description                                     |
|----------------------|---|
| Backing Material     | EcoFlex ONE                                     |
| Fiber Type           | Duracolor® Tricor Premium Nylon                 |
| Dye Method           | Solution Dyed                                   |
| Installation Methods | Monolithic, Half Lap, Brick Ashlar, Basketweave |
| Stitches per Inch    | 13.9 (54.72 per 10cm)                           |
| Density              | 6000  |
| Tufted Pile Weight   | 19.00 oz/yd2 (644 g/m2)                         |
| Surface Texture      | Level Patterned Loop                            |

## Colorways



### Cornflower

Color code: 535  
Style number: GT468

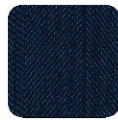

### Royal

Color code: 545  
Style number: GT468



### Flax

Color code: 839  
Style number: GT468



### Taupe

Color code: 859  
Style number: GT468



### Silver

Color code: 929  
Style number: GT468



### Mineral

Color code: 949  
Style number: GT468



### Iron

Color code: 969  
Style number: GT468



### Charcoal

Color code: 989  
Style number: GT468



## Performance

| Feature                          | Description                    |
|----------------------------------|--------------------------------|
| Gauge                            | 1/12 (47.00 rows per 10 cm)    |
| Stain Release Technology         | Pass                           |
| Foot Traffic Recommendation TARR | Heavy                          |
| Flammability                     | ASTM E 648 Class 1 (Glue Down) |
| Smoke Density                    | ASTM E 662 Less than 450       |
| Static Propensity                | AATCC - 134 Under 3.5 KV       |
| Soil Release Technology          | EcoSentry Soil Protection      |

## Sustainability

| Feature                         | Description  |
|---------------------------------|--|
| Beyond Carbon Neutral           | This product is 100% carbon neutral plus an additional 5% offset |
| Carbon Handprint                | -0.031 kg CO <sub>2</sub> e/ft <sup>2</sup>                      |
| Embodied Carbon                 | 0.62 kg CO <sub>2</sub> e/ft <sup>2</sup>                        |
| NSF 140                         | EcoFlex One - NSF 140 Platinum                                   |
| Indoor Air Quality              | <a href="#">GLP 1171</a>   |
| Red List Free                   | True   |
| Declare Label                   | Nylon Modular Carpet on EcoFlex ONE Backing                      |
| Environmental Claims Validation | EPD EcoFlex One  |
| Global Green Tag                | Green Label Plus Certified # 1171                                |

## Warranties

Lifetime Limited Carpet Tile Warranty, Lifetime Limited Duracolor Stain Warranty, Lifetime Static, Lifetime Static



# Thematic Thread

|              |  |
|--------------|--|
| Collection   | Textural Effects                           |
| Style Name   | Thematic Thread                            |
| Style Number | GT423                                      |
| Product Type | Carpet Tile                                |
| Size         | 12" X 36"                                  |
| Construction | Tufted                                     |
| Installation | Monolithic, Half Lap, Brick Ashlar, Basket |



| Feature              | Description                                |
|----------------------|--|
| Backing Material     | EcoFlex NXT                                |
| Fiber Type           | Duracolor® Tricor Premium Nylon            |
| Dye Method           | Solution Dyed                              |
| Installation Methods | Monolithic, Half Lap, Brick Ashlar, Basket |
| Stitches per Inch    | 11.7 (46.06 per 10cm)                      |
| Density              | 7578                                       |
| Tufted Pile Weight   | 20.00 oz/yd2 (678 g/m2)                    |
| Surface Texture      | Textured Patterned Loop                    |

## Colorways



### Larimar

Color code: 549  
Style number: GT423



### Sodalite

Color code: 577  
Style number: GT423

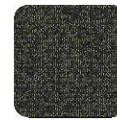

### Olivine

Color code: 667  
Style number: GT423



### Aventurine

Color code: 679  
Style number: GT423



### Diorite

Color code: 739  
Style number: GT423



### Bronzite

Color code: 869  
Style number: GT423



### Granite

Color code: 967  
Style number: GT423



### Concrete

Color code: 968  
Style number: GT423



### Charcoal

Color code: 989  
Style number: GT423



## Performance

| Feature                          | Description                    |
|----------------------------------|--------------------------------|
| Gauge                            | 1/12 (47.00 rows per 10 cm)    |
| Stain Release Technology         | Pass                           |
| Foot Traffic Recommendation TARR | Heavy                          |
| Flammability                     | ASTM E 648 Class 1 (Glue Down) |
| Smoke Density                    | ASTM E 662 Less than 450       |
| Static Propensity                | AATCC-134 Under 3.5 KV         |
| Soil Release Technology          | EcoSentry Soil Protection      |

## Sustainability

| Feature                         | Description  |
|---------------------------------|--|
| Beyond Carbon Neutral           | This product is 100% carbon neutral plus an additional 5% offset |
| Carbon Handprint                | -0.066 kg CO2e/ft2   |
| Embodied Carbon                 | 1.33 kg CO2e/ft2   |
| Total Recycled Content          | 57%  |
| Pre-Consumer Recycled Content   | 57%  |
| NSF 140                         | <a href="#">EcoFlex NXT - NSF 140 Gold</a>                       |
| Indoor Air Quality              | <a href="#">GLP 1171</a>   |
| TVOC Range                      | 0.5 mg/m3 or less  |
| Red List Free                   | True   |
| Declare Label                   | Nylon Modular Carpet on EcoFlex NXT                              |
| Mindful Materials               | Participates in Mindful Materials Library                        |
| Take Back Program               | <a href="#">ReCover Program</a>                                  |
| Health Product Declaration      | <a href="#">HPD 2.1 EcoFlex NXT Gold - 1000 ppm</a>              |
| Environmental Claims Validation | <a href="#">EPD EcoFlex NXT</a>                                  |
| LEED Credit Potential           | LEED Eligible  |

## Warranties

Lifetime Limited Carpet Tile Warranty, Lifetime Limited Duracolor Stain Warranty, Lifetime Static



# Angled Perception

|              |                                       |
|--------------|---------------------------------------|
| Collection   | Visual Edge                           |
| Style Name   | Angled Perception                     |
| Style Number | BT496                                 |
| Product Type | Carpet Tile                           |
| Size         | 12" X 36"                             |
| Construction | Tufted                                |
| Installation | Half Lap, Plank Half Lap, Herringbone |



| Feature              | Description                           |
|----------------------|---------------------------------------|
| Backing Material     | EcoFlex Matrix                        |
| Fiber Type           | ColorStrand® SD Nylon                 |
| Dye Method           | Solution Dyed                         |
| Installation Methods | Half Lap, Plank Half Lap, Herringbone |
| Stitches per Inch    | 11.2 (44.09 per 10cm)                 |
| Density              | 5192                                  |
| Tufted Pile Weight   | 15.00 oz/yd2 (509 g/m2)               |
| Surface Texture      | Textured Patterned Loop               |

## Colorways



### Indigo Ink

Color code: 593  
Style number: BT496



### Warm Neutral

Color code: 929  
Style number: BT496



### Wet Cement

Color code: 937  
Style number: BT496



### Rustic Taupe

Color code: 948  
Style number: BT496



### Metal Grey

Color code: 979  
Style number: BT496

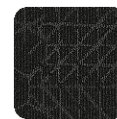

### Dark Charcoal

Color code: 989  
Style number: BT496

## Performance

| Feature                          | Description                    |
|----------------------------------|--------------------------------|
| Gauge                            | 1/12 (47.00 rows per 10 cm)    |
| Foot Traffic Recommendation TARR | Heavy                          |
| Flammability                     | ASTM E 648 Class 1 (Glue Down) |
| Smoke Density                    | ASTM E 662 Less than 450       |
| Static Propensity                | AATCC-134 Under 3.5 KV         |
| Soil Release Technology          | EcoSentry Soil Protection      |



## Sustainability

| Feature                         | Description  |
|---------------------------------|--|
| Beyond Carbon Neutral           | This product is 100% carbon neutral plus an additional 5% offset |
| Carbon Handprint                | -0.053 kg CO2e/ft2   |
| Embodied Carbon                 | 1.06 kg CO2e/ft2   |
| Total Recycled Content          | 52%  |
| Pre-Consumer Recycled Content   | 52%  |
| NSF 140                         | <a href="#">EcoFlex Matrix - NSF 140 Gold</a>                    |
| Indoor Air Quality              | <a href="#">GLP 1171</a>   |
| TVOC Range                      | 0.5 mg/m3 or less  |
| Red List Free                   | True   |
| Declare Label                   | Nylon Modular Carpet on EcoFlex Matrix                           |
| Mindful Materials               | Participates in Mindful Materials Library                        |
| Take Back Program               | <a href="#">ReCover Program</a>                                  |
| Health Product Declaration      | <a href="#">HPD 2.1 EcoFlex Matrix - 1000 ppm</a>                |
| Environmental Claims Validation | <a href="#">EPD EcoFlex Matrix</a>                               |
| LEED Credit Potential           | LEED Eligible  |

## Warranties

Lifetime Limited Carpet Tile Warranty, Lifetime Limited Colorfastness to Light, 10 Year Colorfastness to Atmospheric Contaminants, 10 Year Stain Warranty, 10 Year Limited Static



# Metalmorphic

|              |  |
|--------------|--|
| Collection   | Iconic Earth                               |
| Style Name   | Metalmorphic                               |
| Style Number | BT388                                      |
| Product Type | Carpet Tile                                |
| Size         | 12" X 36"                                  |
| Construction | Tufted                                     |
| Installation | Monolithic, Half Lap, Brick Ashlar, Basket |



| Feature              | Description                                |
|----------------------|--|
| Backing Material     | EcoFlex NXT                                |
| Fiber Type           | ColorStrand® SD Nylon                      |
| Dye Method           | Solution Dyed                              |
| Installation Methods | Monolithic, Half Lap, Brick Ashlar, Basket |
| Stitches per Inch    | 10 (39.37 per 10cm)                        |
| Density              | 8704                                       |
| Tufted Pile Weight   | 16.20 oz/yd2 (549 g/m2)                    |
| Surface Texture      | Textured Patterned Loop                    |

## Colorways



### Rugged Range Metalli

Color code: 152  
Style number: BT388



### Classic Ridge Metall

Color code: 358  
Style number: BT388



### Perfect Paths Metall

Color code: 751  
Style number: BT388



### Downing Stone Metall

Color code: 859  
Style number: BT388



### Canyon Clay Metallic

Color code: 862  
Style number: BT388



### Wild Terrain Metalli

Color code: 883  
Style number: BT388

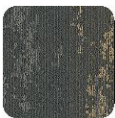

### Solid Ground Metalli

Color code: 955  
Style number: BT388



### Clean Slate Metallic

Color code: 983  
Style number: BT388



### Daring Drift Metalli

Color code: 999  
Style number: BT388





## Performance

| Feature                          | Description                    |
|----------------------------------|--------------------------------|
| Gauge                            | 1/12 (47.00 rows per 10 cm)    |
| Foot Traffic Recommendation TARR | Heavy                          |
| Flammability                     | ASTM E 648 Class 1 (Glue Down) |
| Smoke Density                    | ASTM E 662 Less than 450       |
| Static Propensity                | AATCC-134 Under 3.5 KV         |
| Soil Release Technology          | EcoSentry Soil Protection      |

## Sustainability

| Feature                         | Description  |
|---------------------------------|--|
| Beyond Carbon Neutral           | This product is 100% carbon neutral plus an additional 5% offset |
| Carbon Handprint                | -0.058 kg CO2e/ft2   |
| Embodied Carbon                 | 1.16 kg CO2e/ft2   |
| Total Recycled Content          | 48%  |
| Pre-Consumer Recycled Content   | 48%  |
| NSF 140                         | <a href="#">EcoFlex NXT - NSF 140 Gold</a>                       |
| Indoor Air Quality              | <a href="#">GLP 1171</a>   |
| TVOC Range                      | 0.5 mg/m3 or less  |
| Red List Free                   | True   |
| Declare Label                   | Nylon Modular Carpet on EcoFlex NXT                              |
| Mindful Materials               | Participates in Mindful Materials Library                        |
| Take Back Program               | <a href="#">ReCover Program</a>                                  |
| Health Product Declaration      | <a href="#">HPD 2.1 EcoFlex NXT Gold - 1000 ppm</a>              |
| Environmental Claims Validation | <a href="#">EPD EcoFlex NXT</a>                                  |
| Global Green Tag                | GreenRate Level A, LCARate Silver Plus                           |
| LEED Credit Potential           | LEED Eligible  |

## Warranties

Lifetime Limited Carpet Tile Warranty, Lifetime Limited Colorfastness to Light, 10 Year Limited Colorfastness to Atmospheric Contaminants, 10 Year Limited Stain Warranty



# Hidden Dimension

|              |  |
|--------------|--|
| Collection   | Visual Edge                                |
| Style Name   | Hidden Dimension                           |
| Style Number | BT497                                      |
| Product Type | Carpet Tile                                |
| Size         | 12" X 36"                                  |
| Construction | Tufted                                     |
| Installation | Monolithic, Half Lap, Brick Ashlar, Basket |

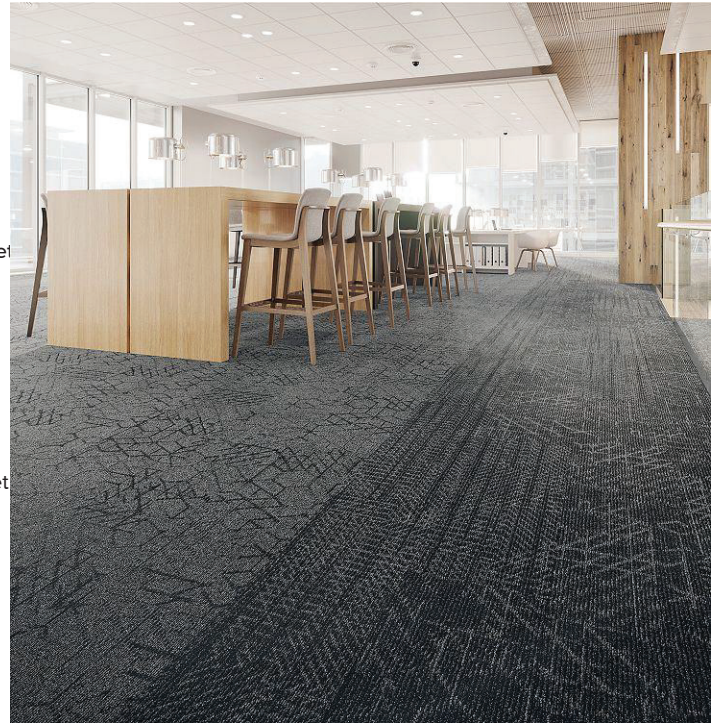

| Feature              | Description                                |
|----------------------|--|
| Backing Material     | EcoFlex Matrix                             |
| Fiber Type           | ColorStrand® SD Nylon                      |
| Dye Method           | Solution Dyed                              |
| Installation Methods | Monolithic, Half Lap, Brick Ashlar, Basket |
| Stitches per Inch    | 11.4 (44.88 per 10cm)                      |
| Density              | 5869                                       |
| Tufted Pile Weight   | 15.00 oz/yd2 (509 g/m2)                    |
| Surface Texture      | Textured Patterned Loop                    |

## Colorways



### Indigo Ink

Color code: 593  
Style number: BT497



### Warm Neutral

Color code: 929  
Style number: BT497



### Wet Cement

Color code: 937  
Style number: BT497



### Rustic Taupe

Color code: 948  
Style number: BT497



### Metal Grey

Color code: 979  
Style number: BT497



### Dark Charcoal

Color code: 989  
Style number: BT497

## Performance

| Feature                          | Description                    |
|----------------------------------|--------------------------------|
| Gauge                            | 1/12 (47.00 rows per 10 cm)    |
| Foot Traffic Recommendation TARR | Heavy                          |
| Flammability                     | ASTM E 648 Class 1 (Glue Down) |
| Smoke Density                    | ASTM E 662 Less than 450       |
| Static Propensity                | AATCC-134 Under 3.5 KV         |
| Soil Release Technology          | EcoSentry Soil Protection      |



## Sustainability

| Feature                         | Description  |
|---------------------------------|--|
| Beyond Carbon Neutral           | This product is 100% carbon neutral plus an additional 5% offset |
| Carbon Handprint                | -0.053 kg CO2e/ft2   |
| Embodied Carbon                 | 1.06 kg CO2e/ft2   |
| Total Recycled Content          | 52%  |
| Pre-Consumer Recycled Content   | 52%  |
| NSF 140                         | <a href="#">EcoFlex Matrix - NSF 140 Gold</a>                    |
| Indoor Air Quality              | <a href="#">GLP 1171</a>   |
| TVOC Range                      | 0.5 mg/m3 or less  |
| Red List Free                   | True   |
| Declare Label                   | Nylon Modular Carpet on EcoFlex Matrix                           |
| Mindful Materials               | Participates in Mindful Materials Library                        |
| Take Back Program               | <a href="#">ReCover Program</a>                                  |
| Health Product Declaration      | <a href="#">HPD 2.1 EcoFlex Matrix - 1000 ppm</a>                |
| Environmental Claims Validation | <a href="#">EPD EcoFlex Matrix</a>                               |
| LEED Credit Potential           | LEED Eligible  |

## Warranties

Lifetime Limited Carpet Tile Warranty, Lifetime Limited Colorfastness to Light, 10 Year Colorfastness to Atmospheric Contaminants, 10 Year Stain Warranty, 10 Year Limited Static



# Urban Terrain

|              |   |
|--------------|---|
| Collection   | Nutopia Matrix                            |
| Style Name   | Urban Terrain                             |
| Style Number | GT413                                     |
| Product Type | Carpet Tile                               |
| Size         | 12" X 36"                                 |
| Construction | Tufted                                    |
| Installation | Half Lap, Brick Ashlar, Basket Weave, Pla |



| Feature              | Description                                      |
|----------------------|--|
| Backing Material     | EcoFlex Matrix                                   |
| Fiber Type           | Duracolor® Tricor Premium Nylon                  |
| Dye Method           | Solution Dyed                                    |
| Installation Methods | Half Lap, Brick Ashlar, Basket Weave, Pla        |
| Stitches per Inch    | 12.2 (48.03 per 10cm)                            |
| Density              | 7058   |
| Tufted Pile Weight   | 20.00 oz/yd <sup>2</sup> (678 g/m <sup>2</sup> ) |
| Surface Texture      | Textured Patterned Loop                          |

## Colorways



### Compose

Color code: 839  
Style number: GT413



### Essential

Color code: 878  
Style number: GT413



### Serene

Color code: 937  
Style number: GT413



### Captivate

Color code: 945  
Style number: GT413



### Idyllic

Color code: 959  
Style number: GT413



### Fusion

Color code: 969  
Style number: GT413



### Connect

Color code: 979  
Style number: GT413



### Intrigue

Color code: 989  
Style number: GT413



## Performance

| Feature                          | Description                    |
|----------------------------------|--------------------------------|
| Gauge                            | 1/12 (47.00 rows per 10 cm)    |
| Stain Release Technology         | Pass                           |
| Foot Traffic Recommendation TARR | Heavy                          |
| Flammability                     | ASTM E 648 Class 1 (Glue Down) |
| Smoke Density                    | ASTM E 662 Less than 450       |
| Static Propensity                | AATCC-134 Under 3.5 KV         |
| Soil Release Technology          | EcoSentry Soil Protection      |

## Sustainability

| Feature                         | Description  |
|---------------------------------|--|
| Beyond Carbon Neutral           | This product is 100% carbon neutral plus an additional 5% offset |
| Carbon Handprint                | -0.063 kg CO2e/ft2   |
| Embodied Carbon                 | 1.27 kg CO2e/ft2   |
| Total Recycled Content          | 51%  |
| Pre-Consumer Recycled Content   | 51%  |
| NSF 140                         | <a href="#">EcoFlex Matrix - NSF 140 Gold</a>                    |
| Indoor Air Quality              | <a href="#">GLP 1171</a>   |
| TVOC Range                      | 0.5 mg/m3 or less  |
| Red List Free                   | True   |
| Declare Label                   | Nylon Modular Carpet on EcoFlex Matrix                           |
| Mindful Materials               | Participates in Mindful Materials Library                        |
| Take Back Program               | <a href="#">ReCover Program</a>                                  |
| Health Product Declaration      | <a href="#">HPD 2.1 EcoFlex Matrix - 1000 ppm</a>                |
| Environmental Claims Validation | <a href="#">EPD EcoFlex Matrix</a>                               |
| LEED Credit Potential           | LEED Eligible  |

## Warranties

Lifetime Limited Carpet Tile Warranty, Lifetime Limited Duracolor Stain Warranty, Lifetime Static



# Urban Transit

|              |  |
|--------------|--|
| Collection   | Nutopia Matrix                             |
| Style Name   | Urban Transit                              |
| Style Number | GT414                                      |
| Product Type | Carpet Tile                                |
| Size         | 12" X 36"                                  |
| Construction | Tufted                                     |
| Installation | Monolithic, Half Lap, Brick Ashlar, Basket |



| Feature              | Description                                      |
|----------------------|--|
| Backing Material     | EcoFlex Matrix                                   |
| Fiber Type           | Duracolor® Tricor Premium Nylon                  |
| Dye Method           | Solution Dyed                                    |
| Installation Methods | Monolithic, Half Lap, Brick Ashlar, Basket       |
| Stitches per Inch    | 12.6 (49.61 per 10cm)                            |
| Density              | 7128   |
| Tufted Pile Weight   | 20.00 oz/yd <sup>2</sup> (678 g/m <sup>2</sup> ) |
| Surface Texture      | Textured Patterned Loop                          |

## Colorways



### Compose

Color code: 839  
Style number: GT414



### Essential

Color code: 878  
Style number: GT414



### Serene

Color code: 937  
Style number: GT414



### Captivate

Color code: 945  
Style number: GT414



### Idyllic

Color code: 959  
Style number: GT414



### Fusion

Color code: 969  
Style number: GT414



### Connect

Color code: 979  
Style number: GT414



### Intrigue

Color code: 989  
Style number: GT414



## Performance

| Feature                          | Description                    |
|----------------------------------|--------------------------------|
| Gauge                            | 1/12 (47.00 rows per 10 cm)    |
| Stain Release Technology         | Pass                           |
| Foot Traffic Recommendation TARR | Heavy                          |
| Flammability                     | ASTM E 648 Class 1 (Glue Down) |
| Smoke Density                    | ASTM E 662 Less than 450       |
| Static Propensity                | AATCC-134 Under 3.5 KV         |
| Soil Release Technology          | EcoSentry Soil Protection      |

## Sustainability

| Feature                         | Description  |
|---------------------------------|--|
| Beyond Carbon Neutral           | This product is 100% carbon neutral plus an additional 5% offset |
| Carbon Handprint                | -0.063 kg CO2e/ft2   |
| Embodied Carbon                 | 1.27 kg CO2e/ft2   |
| Total Recycled Content          | 51%  |
| Pre-Consumer Recycled Content   | 51%  |
| NSF 140                         | <a href="#">EcoFlex Matrix - NSF 140 Gold</a>                    |
| TVOC Range                      | 0.5 mg/m3 or less  |
| Red List Free                   | True   |
| Declare Label                   | Nylon Modular Carpet on EcoFlex Matrix                           |
| Mindful Materials               | Participates in Mindful Materials Library                        |
| Take Back Program               | <a href="#">ReCover Program</a>                                  |
| Health Product Declaration      | <a href="#">HPD 2.1 EcoFlex Matrix - 1000 ppm</a>                |
| Environmental Claims Validation | <a href="#">EPD EcoFlex Matrix</a>                               |
| LEED Credit Potential           | LEED Eligible  |

## Warranties

Lifetime Limited Carpet Tile Warranty, Lifetime Limited Duracolor Stain Warranty, Lifetime Static



# Color Balance

|              |  |
|--------------|--|
| Style Name   | Color Balance                              |
| Style Number | GT405                                      |
| Product Type | Carpet Tile                                |
| Size         | 12" X 36"                                  |
| Construction | Tufted                                     |
| Installation | Monolithic, Half Lap, Brick Ashlar, Basket |



| Feature              | Description                                |
|----------------------|--|
| Backing Material     | EcoFlex NXT                                |
| Fiber Type           | Duracolor® Tricor Premium Nylon            |
| Dye Method           | Solution Dyed                              |
| Installation Methods | Monolithic, Half Lap, Brick Ashlar, Basket |
| Stitches per Inch    | 10.8 (42.52 per 10cm)                      |
| Density              | 5853                                       |
| Tufted Pile Weight   | 20.00 oz/yd2 (678 g/m2)                    |
| Surface Texture      | Textured Patterned Loop                    |

## Colorways

|  |   |   |
|--|---|---|
|  <p><b>Sunlight</b></p> <hr/> <p>Color code: 141<br/>Style number: GT405</p> |  <p><b>Solar</b></p> <hr/> <p>Color code: 252<br/>Style number: GT405</p>    |  <p><b>Atomic</b></p> <hr/> <p>Color code: 373<br/>Style number: GT405</p>     |
|  <p><b>Mystic</b></p> <hr/> <p>Color code: 444<br/>Style number: GT405</p>   |  <p><b>Blossom</b></p> <hr/> <p>Color code: 484<br/>Style number: GT405</p>  |  <p><b>Aquarius</b></p> <hr/> <p>Color code: 545<br/>Style number: GT405</p>   |
|  <p><b>Filtered</b></p> <hr/> <p>Color code: 556<br/>Style number: GT405</p> |  <p><b>Electric</b></p> <hr/> <p>Color code: 566<br/>Style number: GT405</p> |  <p><b>Nightshade</b></p> <hr/> <p>Color code: 575<br/>Style number: GT405</p> |
|  <p><b>Punchy</b></p> <hr/> <p>Color code: 641<br/>Style number: GT405</p>   |  <p><b>Tropic</b></p> <hr/> <p>Color code: 655<br/>Style number: GT405</p>   |  <p><b>Jungle</b></p> <hr/> <p>Color code: 656<br/>Style number: GT405</p>     |
|  <p><b>Bone</b></p> <hr/> <p>Color code: 839<br/>Style number: GT405</p>     |  <p><b>Sand</b></p> <hr/> <p>Color code: 847<br/>Style number: GT405</p>     |  <p><b>Roasted</b></p> <hr/> <p>Color code: 859<br/>Style number: GT405</p>    |
|  <p><b>Chestnut</b></p> <hr/> <p>Color code: 878<br/>Style number: GT405</p> |  <p><b>Optic</b></p> <hr/> <p>Color code: 937<br/>Style number: GT405</p>    |  <p><b>Nickel</b></p> <hr/> <p>Color code: 945<br/>Style number: GT405</p>     |





## Colorways



### Concrete

Color code: 949  
Style number: GT405



### Bedrock

Color code: 959  
Style number: GT405



### Titanium

Color code: 969  
Style number: GT405



### Magnetic

Color code: 979  
Style number: GT405



### Shadow

Color code: 989  
Style number: GT405



### Flame

Color code: 565A  
Style number: GT405

## Performance

| Feature                          | Description                    |
|----------------------------------|--------------------------------|
| Gauge                            | 1/12 (47.00 rows per 10 cm)    |
| Stain Release Technology         | Pass                           |
| Foot Traffic Recommendation TARR | Heavy                          |
| Flammability                     | ASTM E 648 Class 1 (Glue Down) |
| Smoke Density                    | ASTM E 662 Less than 450       |
| Static Propensity                | AATCC-134 Under 3.5 KV         |
| Soil Release Technology          | EcoSentry Soil Protection      |

## Sustainability

| Feature                         | Description  |
|---------------------------------|--|
| Beyond Carbon Neutral           | This product is 100% carbon neutral plus an additional 5% offset |
| Carbon Handprint                | -0.063 kg CO2e/ft2   |
| Embodied Carbon                 | 1.27 kg CO2e/ft2   |
| Total Recycled Content          | 51%  |
| Pre-Consumer Recycled Content   | 51%  |
| NSF 140                         | <a href="#">EcoFlex Matrix - NSF 140 Gold</a>                    |
| TVOC Range                      | 0.5 mg/m3 or less  |
| Red List Free                   | True   |
| Declare Label                   | Nylon Modular Carpet on EcoFlex Matrix                           |
| Mindful Materials               | Participates in Mindful Materials Library                        |
| Take Back Program               | <a href="#">ReCover Program</a>                                  |
| Health Product Declaration      | <a href="#">HPD 2.1 EcoFlex Matrix - 1000 ppm</a>                |
| Environmental Claims Validation | <a href="#">EPD EcoFlex Matrix</a>                               |
| LEED Credit Potential           | LEED Eligible  |

## Warranties

Lifetime Limited Carpet Tile Warranty, Lifetime Limited Duracolor Stain Warranty, Lifetime Static



# Disruptive Path

|              |  |
|--------------|--|
| Collection   | Art Style                                  |
| Style Name   | Disruptive Path                            |
| Style Number | BT430                                      |
| Product Type | Carpet Tile                                |
| Size         | 12" X 36"                                  |
| Construction | Tufted                                     |
| Installation | Monolithic, Half Lap, Brick Ashlar, Basket |

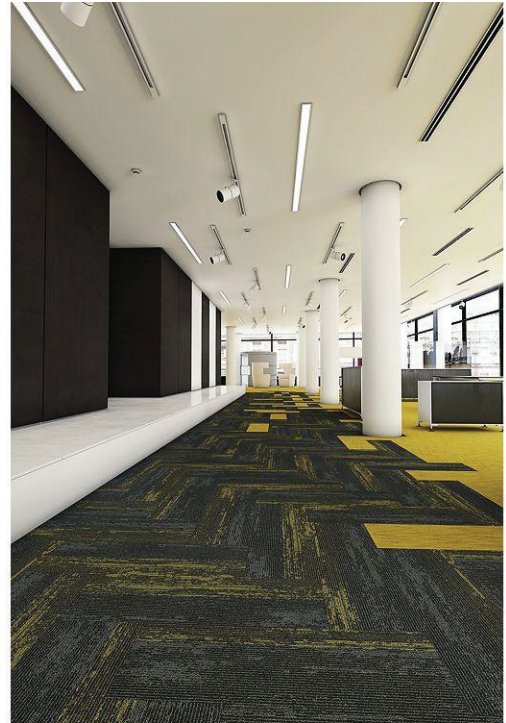

| Feature              | Description                                |
|----------------------|--|
| Backing Material     | EcoFlex NXT                                |
| Fiber Type           | ColorStrand® SD Nylon                      |
| Dye Method           | Solution Dyed                              |
| Installation Methods | Monolithic, Half Lap, Brick Ashlar, Basket |
| Stitches per Inch    | 12 (47.24 per 10cm)                        |
| Density              | 7285                                       |
| Tufted Pile Weight   | 17.00 oz/yd2 (576 g/m2)                    |
| Surface Texture      | Level Multi-Colored Patterned Loop         |

## Colorways



### Mellow Yellow

Color code: 911  
Style number: BT430



### Orange Crush

Color code: 913  
Style number: BT430



### Purple Dawn

Color code: 914  
Style number: BT430



### Blue Dusk

Color code: 915  
Style number: BT430



### Lime Rush

Color code: 916  
Style number: BT430



### Pink Berry

Color code: 919  
Style number: BT430



### Neon Citron

Color code: 931  
Style number: BT430



### Crimson Flash

Color code: 933  
Style number: BT430



### Cotton Candy

Color code: 944  
Style number: BT430



### Above Par

Color code: 946  
Style number: BT430



### Purple Ash

Color code: 954  
Style number: BT430



### Cosmic Sky

Color code: 955  
Style number: BT430



## Performance

| Feature                          | Description                    |
|----------------------------------|--------------------------------|
| Gauge                            | 1/12 (47.00 rows per 10 cm)    |
| Stain Release Technology         | Pass                           |
| Foot Traffic Recommendation TARR | Heavy                          |
| Flammability                     | ASTM E 648 Class 1 (Glue Down) |
| Smoke Density                    | ASTM E 662 Less than 450       |
| Static Propensity                | AATCC-134 Under 3.5 KV         |
| Soil Release Technology          | EcoSentry Soil Protection      |

## Sustainability

| Feature                         | Description  |
|---------------------------------|--|
| Beyond Carbon Neutral           | This product is 100% carbon neutral plus an additional 5% offset |
| Carbon Handprint                | -0.06 kg CO2e/ft2  |
| Embodied Carbon                 | 1.2 kg CO2e/ft2  |
| Total Recycled Content          | 61%  |
| Pre-Consumer Recycled Content   | 61%  |
| NSF 140                         | <a href="#">EcoFlex NXT - NSF 140 Gold</a>                       |
| Indoor Air Quality              | <a href="#">GLP 1171</a>   |
| TVOC Range                      | 0.5 mg/m3 or less  |
| Red List Free                   | True   |
| Declare Label                   | Nylon Modular Carpet on EcoFlex NXT                              |
| Mindful Materials               | Participates in Mindful Materials Library                        |
| Take Back Program               | <a href="#">ReCover Program</a>                                  |
| Health Product Declaration      | <a href="#">HPD 2.1 EcoFlex NXT Gold - 1000 ppm</a>              |
| Environmental Claims Validation | <a href="#">EPD EcoFlex NXT</a>                                  |
| Global Green Tag                | GreenRate Level A, LCARate Silver Plus                           |
| LEED Credit Potential           | LEED Eligible  |

## Warranties

Lifetime Limited Carpet Tile Warranty, Lifetime Limited Colorfastness to Light, 10 Year Colorfastness to Atmospheric Contaminants, 10 Year Stain Warranty, Lifetime Static



# Visual Connections

|              |  |
|--------------|--|
| Collection   | Timeless Tailored                          |
| Style Name   | Visual Connections                         |
| Style Number | GT470                                      |
| Product Type | Carpet Tile                                |
| Size         | 12" X 36"                                  |
| Construction | Tufted                                     |
| Installation | Monolithic, Half Lap, Brick Ashlar, Basket |



| Feature              | Description                                |
|----------------------|--|
| Backing Material     | EcoFlex ONE                                |
| Fiber Type           | Duracolor® Tricor Premium Nylon            |
| Dye Method           | Solution Dyed                              |
| Installation Methods | Monolithic, Half Lap, Brick Ashlar, Basket |
| Stitches per Inch    | 13.5 (53.15 per 10cm)                      |
| Density              | 6893                                       |
| Tufted Pile Weight   | 18.00 oz/yd2 (610 g/m2)                    |
| Surface Texture      | Level Patterned Loop                       |

## Colorways



### Cornflower

Color code: 535  
Style number: GT470



### Royal

Color code: 545  
Style number: GT470



### Flax

Color code: 839  
Style number: GT470



### Taupe

Color code: 859  
Style number: GT470



### Silver

Color code: 929  
Style number: GT470



### Mineral

Color code: 949  
Style number: GT470



### Iron

Color code: 969  
Style number: GT470



### Charcoal

Color code: 989  
Style number: GT470



## Performance

| Feature                          | Description                    |
|----------------------------------|--------------------------------|
| Gauge                            | 1/12 (47.00 rows per 10 cm)    |
| Stain Release Technology         | Pass                           |
| Foot Traffic Recommendation TARR | Heavy                          |
| Flammability                     | ASTM E 648 Class 1 (Glue Down) |
| Smoke Density                    | ASTM E 662 Less than 450       |
| Static Propensity                | AATCC - 134 Under 3.5 KV       |
| Soil Release Technology          | EcoSentry Soil Protection      |

## Sustainability

| Feature                         | Description  |
|---------------------------------|--|
| Beyond Carbon Neutral           | This product is 100% carbon neutral plus an additional 5% offset |
| Carbon Handprint                | -0.03 kg CO2e/ft2  |
| Embodied Carbon                 | 0.61 kg CO2e/ft2   |
| NSF 140                         | EcoFlex One - NSF 140 Platinum                                   |
| Indoor Air Quality              | <a href="#">GLP 1171</a>   |
| Red List Free                   | True   |
| Declare Label                   | Nylon Modular Carpet on EcoFlex ONE Backing                      |
| Environmental Claims Validation | EPD EcoFlex One  |
| Global Green Tag                | Green Label Plus Certified # 1171                                |

## Warranties

Lifetime Limited Carpet Tile Warranty, Lifetime Limited Duracolor Stain Warranty, Lifetime Static, Lifetime Static



# Mirada Stitchlock

|              |                   |
|--------------|-------------------|
| Collection   | Learn and Live    |
| Style Name   | Mirada Stitchlock |
| Style Number | GL417             |
| Product Type | Broadloom         |
| Size         | 12Ft 00In         |
| Construction | Tufted            |
| Installation | Monolithic        |



| Feature              | Description                     |
|----------------------|---------------------------------|
| Backing Material     | Unibond® Plus                   |
| Fiber Type           | Duracolor® Tricor Premium Nylon |
| Dye Method           | Solution Dyed                   |
| Installation Methods | Monolithic                      |
| Stitches per Inch    | 8.67 (34.12 per 10cm)           |
| Density              | 8400                            |
| Tufted Pile Weight   | 28.00 oz/yd2 (949 g/m2)         |
| Surface Texture      | Textured Patterned Loop         |

## Colorways



### Perfect Compliment

Color code: 562  
Style number: GL417



### Blue Blood

Color code: 575  
Style number: GL417



### Cherry Tree

Color code: 853  
Style number: GL417



### Moth Wing

Color code: 878  
Style number: GL417



### Dynamo

Color code: 963  
Style number: GL417



### Lemon Twist

Color code: 971  
Style number: GL417



### Mindful Grey

Color code: 989  
Style number: GL417



## Performance

| Feature                          | Description                    |
|----------------------------------|--------------------------------|
| Gauge                            | 1/12 (47.00 rows per 10 cm)    |
| Stain Release Technology         | Pass                           |
| Foot Traffic Recommendation TARR | Severe                         |
| Flammability                     | ASTM E 648 Class 1 (Glue Down) |
| Smoke Density                    | ASTM E 662 Less than 450       |
| Static Propensity                | AATCC-134 Under 3.5 KV         |
| Pattern Repeat                   | 7.2"W X 8.3"L                  |
| Soil Release Technology          | EcoSentry Soil Protection      |

## Sustainability

| Feature                         | Description  |
|---------------------------------|--|
| Beyond Carbon Neutral           | This product is 100% carbon neutral plus an additional 5% offset |
| Carbon Handprint                | -0.058 kg CO2e/ft2   |
| Embodied Carbon                 | 1.15 kg CO2e/ft2   |
| Total Recycled Content          | 39%  |
| Pre-Consumer Recycled Content   | 39%  |
| NSF 140                         | <a href="#">Unibond Plus - NSF 140 Gold</a>                      |
| Indoor Air Quality              | <a href="#">GLP 3802</a>   |
| TVOC Range                      | 0.5 mg/m3 - 5.0 mg/m3  |
| Red List Free                   | True   |
| Declare Label                   | Broadloom Carpet on Unibond® Plus                                |
| Mindful Materials               | Participates in Mindful Materials Library                        |
| Take Back Program               | <a href="#">ReCover Program</a>                                  |
| Health Product Declaration      | <a href="#">HPD 2.1 Unibond Plus - 1000 ppm</a>                  |
| Environmental Claims Validation | <a href="#">EPD Unibond Plus</a>                                 |
| LEED Credit Potential           | LEED Eligible  |

## Warranties

Lifetime Limited Unibond® Plus Warranty, Lifetime Duracolor Stain Warranty, Lifetime Static



# Must Have

|              |               |
|--------------|---------------|
| Collection   | Of The Moment |
| Style Name   | Must Have     |
| Style Number | BC287         |
| Product Type | Broadloom     |
| Size         | 12Ft 00In     |
| Construction | Tufted        |
| Installation | Monolithic    |

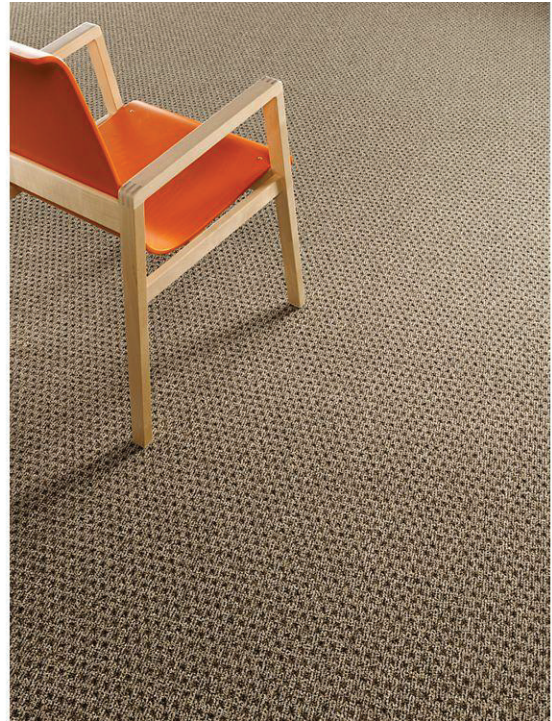

| Feature              | Description             |
|----------------------|-------------------------|
| Backing Material     | Weldlok®                |
| Fiber Type           | ColorStrand® SD Nylon   |
| Dye Method           | Solution Dyed           |
| Installation Methods | Monolithic              |
| Stitches per Inch    | 9 (35.43 per 10cm)      |
| Density              | 6406                    |
| Tufted Pile Weight   | 21.00 oz/yd2 (712 g/m2) |
| Surface Texture      | Textured Heathered Loop |

## Colorways



### Forward Bound

Color code: 7559  
Style number: BC287



### Jump Start

Color code: 7679  
Style number: BC287



### Self Expressions

Color code: 7714  
Style number: BC287



### Suit Yourself

Color code: 7822  
Style number: BC287



### Anything Goes

Color code: 7828  
Style number: BC287



### Go Forth

Color code: 7837  
Style number: BC287



### Artfully Done

Color code: 7838  
Style number: BC287



### Smart Choice

Color code: 7928  
Style number: BC287



### Style Shaper

Color code: 7958  
Style number: BC287



### Defining Moment

Color code: 7959  
Style number: BC287



### Checking In

Color code: 7978  
Style number: BC287





## Performance

| Feature                          | Description                    |
|----------------------------------|--------------------------------|
| Gauge                            | 1/12 (47.00 rows per 10 cm)    |
| Foot Traffic Recommendation TARR | Heavy                          |
| Flammability                     | ASTM E 648 Class 1 (Glue Down) |
| Smoke Density                    | ASTM E 662 Less than 450       |
| Static Propensity                | AATCC-134 Under 3.5 KV         |
| Pattern Repeat                   | 0.8"W X 1.55"L                 |
| Soil Release Technology          | EcoSentry Soil Protection      |

## Sustainability

| Feature                         | Description  |
|---------------------------------|--|
| Beyond Carbon Neutral           | This product is 100% carbon neutral plus an additional 5% offset |
| Carbon Handprint                | -0.046 kg CO2e/ft2   |
| Embodied Carbon                 | 0.93 kg CO2e/ft2   |
| Total Recycled Content          | 51%  |
| Pre-Consumer Recycled Content   | 51%  |
| NSF 140                         | <a href="#">Weldlok - NSF 140 Gold</a>                           |
| Indoor Air Quality              | <a href="#">GLP 8216</a>   |
| TVOC Range                      | 0.5 mg/m3 - 5.0 mg/m3  |
| Red List Free                   | True   |
| Declare Label                   | Broadloom Carpet on Weldlok®                                     |
| Mindful Materials               | Participates in Mindful Materials Library                        |
| Take Back Program               | <a href="#">ReCover Program</a>                                  |
| Health Product Declaration      | <a href="#">HPD 2.1 Weldlok - 1000 ppm</a>                       |
| Environmental Claims Validation | <a href="#">EPD Tufted Broadloom on Weldlok</a>                  |
| LEED Credit Potential           | LEED Eligible  |

## Warranties

Lifetime Limited Wear Warranty, Lifetime Limited Colorfastness to Light, 10 Year Limited Colorfastness to Atmospheric Contaminants, 10 Year Limited Stain Warranty, Lifetime Static



# Broken Checks

|              |               |
|--------------|---------------|
| Collection   | Intertwined   |
| Style Name   | Broken Checks |
| Style Number | BC403         |
| Product Type | Broadloom     |
| Size         | 12Ft 00In     |
| Construction | Tufted        |
| Installation | Monolithic    |



| Feature              | Description                   |
|----------------------|-------------------------------|
| Backing Material     | Unibond® Plus                 |
| Fiber Type           | ColorStrand® SD Nylon         |
| Dye Method           | Solution Dyed                 |
| Installation Methods | Monolithic                    |
| Stitches per Inch    | 10.83 (42.65 per 10cm)        |
| Density              | 9679                          |
| Tufted Pile Weight   | 28.50 oz/yd2 (966 g/m2)       |
| Surface Texture      | Textured Patterned Cut & Loop |

## Colorways

|  |   |  |
|--|---|--|
|  <b>Overlay</b><br>Color code: 141<br>Style number: BC403  |  <b>Poplin</b><br>Color code: 365<br>Style number: BC403   |  <b>Trim</b><br>Color code: 553<br>Style number: BC403    |
|  <b>Stitches</b><br>Color code: 641<br>Style number: BC403 |  <b>Blending</b><br>Color code: 858<br>Style number: BC403 |  <b>Thimble</b><br>Color code: 859<br>Style number: BC403 |
|  <b>Gather</b><br>Color code: 869<br>Style number: BC403   |  <b>Facing</b><br>Color code: 889<br>Style number: BC403   |  <b>Thread</b><br>Color code: 945<br>Style number: BC403  |
|  <b>Binding</b><br>Color code: 948<br>Style number: BC403  |  <b>Needle</b><br>Color code: 965<br>Style number: BC403   |  <b>Pique</b><br>Color code: 989<br>Style number: BC403   |



## Performance

| Feature                          | Description                    |
|----------------------------------|--------------------------------|
| Gauge                            | 1/12 (47.00 rows per 10 cm)    |
| Foot Traffic Recommendation TARR | Heavy                          |
| Flammability                     | ASTM E 648 Class 1 (Glue Down) |
| Smoke Density                    | ASTM E 662 Less than 450       |
| Static Propensity                | AATCC-134 Under 3.5 KV         |
| Pattern Repeat                   | 3"W X 6.5"L                    |
| Soil Release Technology          | EcoSentry Soil Protection      |

## Sustainability

| Feature                         | Description  |
|---------------------------------|--|
| Beyond Carbon Neutral           | This product is 100% carbon neutral plus an additional 5% offset |
| Carbon Handprint                | -0.058 kg CO2e/ft2   |
| Embodied Carbon                 | 1.15 kg CO2e/ft2   |
| Total Recycled Content          | 39%  |
| Pre-Consumer Recycled Content   | 39%  |
| NSF 140                         | <a href="#">Unibond Plus - NSF 140 Gold</a>                      |
| Indoor Air Quality              | <a href="#">GLP 3802</a>   |
| TVOC Range                      | 0.5 mg/m3 - 5.0 mg/m3  |
| Red List Free                   | True   |
| Declare Label                   | Broadloom Carpet on Unibond® Plus                                |
| Mindful Materials               | Participates in Mindful Materials Library                        |
| Take Back Program               | <a href="#">ReCover Program</a>                                  |
| Health Product Declaration      | <a href="#">HPD 2.1 Unibond Plus - 1000 ppm</a>                  |
| Environmental Claims Validation | <a href="#">EPD Unibond Plus</a>                                 |
| LEED Credit Potential           | LEED Eligible  |

## Warranties

Lifetime Limited Unibond® Plus Warranty, Lifetime Limited Colorfastness to Light, 10 Year Limited Colorfastness to Atmospheric Contaminants, 10 Year Limited Stain Warranty, Lifetime Static







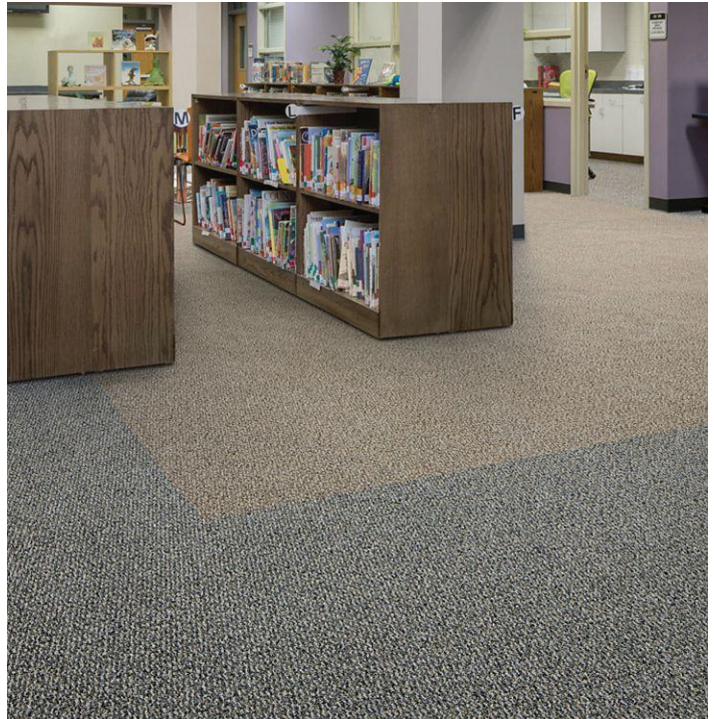



# Connetic

|              |            |
|--------------|------------|
| Style Name   | Connetic   |
| Style Number | BC426      |
| Product Type | Broadloom  |
| Size         | 12Ft 00In  |
| Construction | Tufted     |
| Installation | Monolithic |



| Feature              | Description             |
|----------------------|-------------------------|
| Backing Material     | Unibond® Plus           |
| Fiber Type           | ColorStrand® SD Nylon   |
| Dye Method           | Solution Dyed           |
| Installation Methods | Monolithic              |
| Stitches per Inch    | 11 (43.31 per 10cm)     |
| Density              | 7251                    |
| Tufted Pile Weight   | 28.00 oz/yd2 (949 g/m2) |
| Surface Texture      | Textured Patterned Loop |

## Colorways

|   |  |   |
|---|--|---|
|  <p><b>Intuitive</b></p> <hr/> <p>Color code: 589<br/>Style number: BC426</p>   |  <p><b>Perceptive</b></p> <hr/> <p>Color code: 689<br/>Style number: BC426</p>  |  <p><b>Conscious</b></p> <hr/> <p>Color code: 719<br/>Style number: BC426</p>  |
|  <p><b>Observant</b></p> <hr/> <p>Color code: 837<br/>Style number: BC426</p>   |  <p><b>Instinctive</b></p> <hr/> <p>Color code: 879<br/>Style number: BC426</p> |  <p><b>Reasoning</b></p> <hr/> <p>Color code: 928<br/>Style number: BC426</p>  |
|  <p><b>Spontaneous</b></p> <hr/> <p>Color code: 965<br/>Style number: BC426</p> |  <p><b>Visceral</b></p> <hr/> <p>Color code: 978<br/>Style number: BC426</p>    |  <p><b>Conceptual</b></p> <hr/> <p>Color code: 989<br/>Style number: BC426</p> |



## Performance

| Feature                          | Description                    |
|----------------------------------|--------------------------------|
| Gauge                            | 1/12 (47.00 rows per 10 cm)    |
| Foot Traffic Recommendation TARR | Heavy                          |
| Flammability                     | ASTM E 648 Class 1 (Glue Down) |
| Smoke Density                    | ASTM E 662 Less than 450       |
| Static Propensity                | AATCC-134 Under 3.5 KV         |
| Pattern Repeat                   | NONE                           |
| Soil Release Technology          | EcoSentry Soil Protection      |

## Sustainability

| Feature                         | Description  |
|---------------------------------|--|
| Beyond Carbon Neutral           | This product is 100% carbon neutral plus an additional 5% offset |
| Carbon Handprint                | -0.058 kg CO2e/ft2   |
| Embodied Carbon                 | 1.15 kg CO2e/ft2   |
| Total Recycled Content          | 37%  |
| Pre-Consumer Recycled Content   | 37%  |
| NSF 140                         | <a href="#">Unibond Plus - NSF 140 Gold</a>                      |
| Indoor Air Quality              | <a href="#">GLP 3802</a>   |
| TVOC Range                      | 0.5 mg/m3 - 5.0 mg/m3  |
| Red List Free                   | True   |
| Declare Label                   | Broadloom Carpet on Unibond® Plus                                |
| Mindful Materials               | Participates in Mindful Materials Library                        |
| Take Back Program               | <a href="#">ReCover Program</a>                                  |
| Health Product Declaration      | <a href="#">HPD 2.1 Unibond Plus - 1000 ppm</a>                  |
| Environmental Claims Validation | <a href="#">EPD Unibond Plus</a>                                 |
| LEED Credit Potential           | LEED Eligible  |

## Warranties

Lifetime Limited Wear Warranty, Lifetime Limited Colorfastness to Light, 10 Year Colorfastness to Atmospheric Contaminants, 10 Year Stain Warranty, Lifetime Static



# Enlivened

|              |   |
|--------------|---|
| Collection   | Art Exposure                                |
| Style Name   | Enlivened                                   |
| Style Number | BT455                                       |
| Product Type | Carpet Tile                                 |
| Size         | 24" X 24"                                   |
| Construction | Tufted                                      |
| Installation | Quarter Turn, Vertical Ashlar, Brick Ashlar |

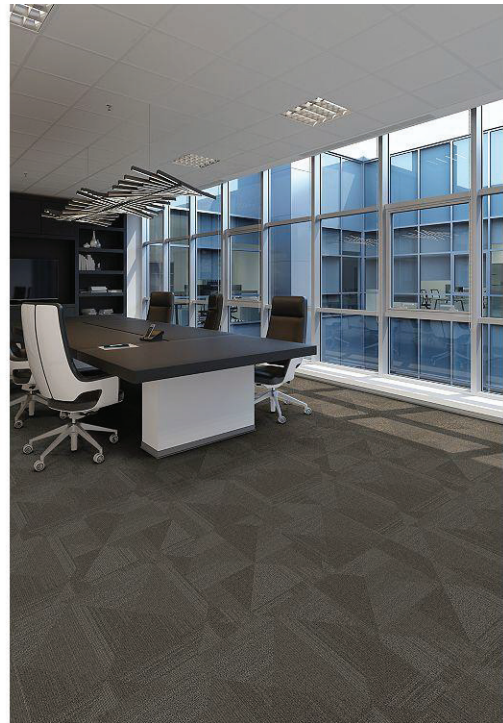

| Feature              | Description                                 |
|----------------------|---|
| Overall Thickness    | .196" (4.98 mm)                             |
| Backing Material     | EcoFlex Matrix                              |
| Fiber Type           | ColorStrand® SD Nylon                       |
| Dye Method           | Solution Dyed                               |
| Installation Methods | Quarter Turn, Vertical Ashlar, Brick Ashlar |
| Stitches per Inch    | 12 (47.24 per 10cm)                         |
| Density              | 6580  |
| Tufted Pile Weight   | 17.00 oz/yd2 (576 g/m2)                     |
| Surface Texture      | Textured Patterned Multi-Colored Loop       |

## Colorways

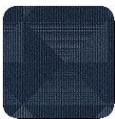

### Cadet

Color code: 569  
Style number: BT455

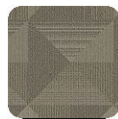

### Fallow

Color code: 853  
Style number: BT455



### Platinum

Color code: 924  
Style number: BT455



### Ecru

Color code: 958  
Style number: BT455

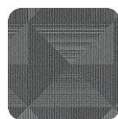

### Slate

Color code: 959  
Style number: BT455

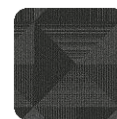

### Charcoal

Color code: 989  
Style number: BT455

## Performance

| Feature                          | Description                    |
|----------------------------------|--------------------------------|
| Gauge                            | 1/12 (47.00 rows per 10 cm)    |
| Foot Traffic Recommendation TARR | Heavy                          |
| Flammability                     | ASTM E 648 Class 1 (Glue Down) |
| Smoke Density                    | ASTM E 662 Less than 450       |
| Static Propensity                | AATCC-134 Under 3.5 KV         |
| Soil Release Technology          | EcoSentry Soil Protection      |



## Sustainability

| Feature                         | Description  |
|---------------------------------|--|
| Beyond Carbon Neutral           | This product is 100% carbon neutral plus an additional 5% offset |
| Carbon Handprint                | -0.057 kg CO2e/ft2   |
| Embodied Carbon                 | 1.14 kg CO2e/ft2   |
| Total Recycled Content          | 52%  |
| Pre-Consumer Recycled Content   | 52%  |
| NSF 140                         | <a href="#">EcoFlex Matrix - NSF 140 Gold</a>                    |
| Indoor Air Quality              | <a href="#">GLP 1171</a>   |
| TVOC Range                      | 0.5 mg/m3 or less  |
| Red List Free                   | True   |
| Declare Label                   | Nylon Modular Carpet on EcoFlex Matrix                           |
| Mindful Materials               | Participates in Mindful Materials Library                        |
| Take Back Program               | <a href="#">ReCover Program</a>                                  |
| Health Product Declaration      | <a href="#">HPD 2.1 EcoFlex Matrix - 1000 ppm</a>                |
| Environmental Claims Validation | <a href="#">EPD EcoFlex Matrix</a>                               |
| LEED Credit Potential           | LEED Eligible  |

## Warranties

Lifetime Limited Carpet Tile Warranty, Lifetime Limited Colorfastness to Light, 10 Year Colorfastness to Atmospheric Contaminants, 10 Year Stain Warranty, Lifetime Static



# Side Stripe

|              |   |
|--------------|---|
| Collection   | Learn and Live                              |
| Style Name   | Side Stripe                                 |
| Style Number | GT419                                       |
| Product Type | Carpet Tile                                 |
| Size         | 24" X 24"                                   |
| Construction | Tufted                                      |
| Installation | Quarter Turn, Vertical Ashlar, Brick Ashlar |



| Feature              | Description                                      |
|----------------------|--|
| Backing Material     | EcoFlex ONE                                      |
| Fiber Type           | Duracolor® Tricor Premium Nylon                  |
| Dye Method           | Solution Dyed                                    |
| Installation Methods | Quarter Turn, Vertical Ashlar, Brick Ashlar      |
| Stitches per Inch    | 12.4 (48.82 per 10cm)                            |
| Density              | 6000   |
| Tufted Pile Weight   | 17.00 oz/yd <sup>2</sup> (576 g/m <sup>2</sup> ) |
| Surface Texture      | Textured Patterned Loop                          |

## Colorways



### City Park

Color code: 562  
Style number: GT419



### Central

Color code: 566  
Style number: GT419



### Fairview

Color code: 853  
Style number: GT419



### Franklin

Color code: 859  
Style number: GT419



### Eastside

Color code: 961  
Style number: GT419



### Heritage

Color code: 963  
Style number: GT419



### Southeast

Color code: 964  
Style number: GT419



### Westpoint

Color code: 965  
Style number: GT419





## Performance

| Feature                          | Description                    |
|----------------------------------|--------------------------------|
| Gauge                            | 1/12 (47.00 rows per 10 cm)    |
| Stain Release Technology         | Pass                           |
| Foot Traffic Recommendation TARR | Severe                         |
| Flammability                     | ASTM E 648 Class 1 (Glue Down) |
| Smoke Density                    | ASTM E 662 Less than 450       |
| Static Propensity                | AATCC-134 Under 3.5 KV         |
| Soil Release Technology          | EcoSentry Soil Protection      |

## Sustainability

| Feature                         | Description  |
|---------------------------------|--|
| Beyond Carbon Neutral           | This product is 100% carbon neutral plus an additional 5% offset |
| Carbon Handprint                | -0.06 kg CO2e/ft2  |
| Embodied Carbon                 | 1.2 kg CO2e/ft2  |
| Total Recycled Content          | 59%  |
| Pre-Consumer Recycled Content   | 59%  |
| NSF 140                         | EcoFlex ONE - NSF 140 Gold                                       |
| Indoor Air Quality              | <a href="#">GLP 1171</a>   |
| TVOC Range                      | 0.5 mg/m3 or less  |
| Red List Free                   | True   |
| Mindful Materials               | Participates in Mindful Materials Library                        |
| Take Back Program               | <a href="#">ReCover Program</a>                                  |
| Health Product Declaration      | HPD 2.1 EcoFlex ONE Gold - 1000 ppm                              |
| Environmental Claims Validation | EPD EcoFlex ONE  |
| Global Green Tag                | GreenRate Level A, LCARate Silver Plus                           |
| LEED Credit Potential           | LEED Eligible  |

## Warranties

Lifetime Limited Carpet Tile Warranty, Lifetime Duracolor Stain Warranty, Lifetime Static



# Venturesome

|              |  |
|--------------|--|
| Collection   | Renegade                                   |
| Style Name   | Venturesome                                |
| Style Number | BT356                                      |
| Product Type | Carpet Tile                                |
| Size         | 24" X 24"                                  |
| Construction | Tufted                                     |
| Installation | Vertical Ashlar, Quarter Turn, Multi-Direc |



| Feature              | Description                                 |
|----------------------|---|
| Backing Material     | EcoFlex Matrix                              |
| Fiber Type           | ColorStrand® SD Nylon                       |
| Dye Method           | Solution Dyed                               |
| Installation Methods | Vertical Ashlar, Quarter Turn, Multi-Direct |
| Stitches per Inch    | 9.6 (37.8 per 10cm)                         |
| Density              | 6195  |
| Surface Texture      | Textured Patterned Loop                     |

## Colorways



### Living Fast

Color code: 152  
Style number: BT356



### Thrill Seeker

Color code: 358  
Style number: BT356



### Glory Days

Color code: 859  
Style number: BT356



### Tough Guy

Color code: 862  
Style number: BT356



### Wild Thing

Color code: 883  
Style number: BT356

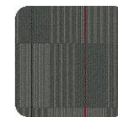

### Cool Hand

Color code: 955  
Style number: BT356

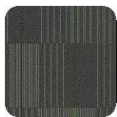

### Roust About

Color code: 983  
Style number: BT356

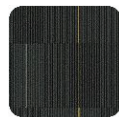

### Leather Jacket

Color code: 999  
Style number: BT356



### Dare Devil

Color code: 751A  
Style number: BT356



## Performance

| Feature                          | Description                    |
|----------------------------------|--------------------------------|
| Gauge                            | 1/12 (47.00 rows per 10 cm)    |
| Foot Traffic Recommendation TARR | Severe                         |
| Flammability                     | ASTM E 648 Class 1 (Glue Down) |
| Smoke Density                    | ASTM E 662 Less than 450       |
| Static Propensity                | AATCC-134 Under 3.5 KV         |
| Soil Release Technology          | EcoSentry Soil Protection      |

## Sustainability

| Feature                         | Description  |
|---------------------------------|--|
| Beyond Carbon Neutral           | This product is 100% carbon neutral plus an additional 5% offset |
| Carbon Handprint                | -0.055 kg CO2e/ft2   |
| Embodied Carbon                 | 1.1 kg CO2e/ft2  |
| Total Recycled Content          | 48%  |
| Pre-Consumer Recycled Content   | 48%  |
| NSF 140                         | <a href="#">EcoFlex Matrix - NSF 140 Gold</a>                    |
| TVOC Range                      | 0.5 mg/m3 or less  |
| Red List Free                   | True   |
| Declare Label                   | Nylon Modular Carpet on EcoFlex Matrix                           |
| Mindful Materials               | Participates in Mindful Materials Library                        |
| Take Back Program               | <a href="#">ReCover Program</a>                                  |
| Health Product Declaration      | <a href="#">HPD 2.1 EcoFlex Matrix - 1000 ppm</a>                |
| Environmental Claims Validation | <a href="#">EPD EcoFlex Matrix</a>                               |
| Global Green Tag                | GreenRate Level A, LCARate Silver Plus                           |
| LEED Credit Potential           | LEED Eligible  |

## Warranties

Lifetime Limited Carpet Tile Warranty, Lifetime Limited Colorfastness to Light, 10 Year Limited Colorfastness to Atmospheric Contaminants, 10 Year Limited Stain Warranty, Lifetime Static



# Insurgent

|              |  |
|--------------|--|
| Collection   | Renegade                                     |
| Style Name   | Insurgent                                    |
| Style Number | BT367  |
| Product Type | Carpet Tile                                  |
| Size         | 24" X 24"                                    |
| Construction | Tufted                                       |
| Installation | Monolithic, Vertical Ashlar, Brick Ashlar, C |



| Feature              | Description                                  |
|----------------------|--|
| Backing Material     | EcoFlex Matrix                               |
| Fiber Type           | ColorStrand® SD Nylon                        |
| Dye Method           | Solution Dyed                                |
| Installation Methods | Monolithic, Vertical Ashlar, Brick Ashlar, C |
| Stitches per Inch    | 10.2 (40.16 per 10cm)                        |
| Density              | 5000   |
| Tufted Pile Weight   | 14.80 oz/yd2 (502 g/m2)                      |
| Surface Texture      | Textured Patterned Loop                      |

## Colorways



### Living Fast

Color code: 152  
Style number: BT367

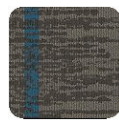

### Thrill Seeker

Color code: 358  
Style number: BT367



### Dare Devil

Color code: 751  
Style number: BT367



### Glory Days

Color code: 859  
Style number: BT367



### Tough Guy

Color code: 862  
Style number: BT367



### Wild Thing

Color code: 883  
Style number: BT367

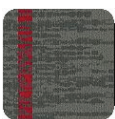

### Cool Hand

Color code: 955  
Style number: BT367

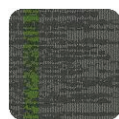

### Roust About

Color code: 983  
Style number: BT367

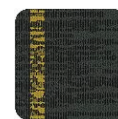

### Leather Jacket

Color code: 999  
Style number: BT367



## Performance

| Feature                          | Description                    |
|----------------------------------|--------------------------------|
| Gauge                            | 1/12 (47.00 rows per 10 cm)    |
| Foot Traffic Recommendation TARR | Heavy                          |
| Flammability                     | ASTM E 648 Class 1 (Glue Down) |
| Smoke Density                    | ASTM E 662 Less than 450       |
| Static Propensity                | AATCC-134 Under 3.5 KV         |
| Soil Release Technology          | EcoSentry Soil Protection      |

## Sustainability

| Feature                         | Description  |
|---------------------------------|--|
| Beyond Carbon Neutral           | This product is 100% carbon neutral plus an additional 5% offset |
| Carbon Handprint                | -0.053 kg CO2e/ft2   |
| Embodied Carbon                 | 1.06 kg CO2e/ft2   |
| Total Recycled Content          | 48%  |
| Pre-Consumer Recycled Content   | 48%  |
| NSF 140                         | <a href="#">EcoFlex Matrix - NSF 140 Gold</a>                    |
| TVOC Range                      | 0.5 mg/m3 or less  |
| Red List Free                   | True   |
| Declare Label                   | Nylon Modular Carpet on EcoFlex Matrix                           |
| Mindful Materials               | Participates in Mindful Materials Library                        |
| Take Back Program               | <a href="#">ReCover Program</a>                                  |
| Health Product Declaration      | <a href="#">HPD 2.1 EcoFlex Matrix - 1000 ppm</a>                |
| Environmental Claims Validation | <a href="#">EPD EcoFlex Matrix</a>                               |
| Global Green Tag                | GreenRate Level A, LCARate Silver Plus                           |
| LEED Credit Potential           | LEED Eligible  |

## Warranties

Lifetime Limited Carpet Tile Warranty, Lifetime Limited Colorfastness to Light, 10 Year Limited Colorfastness to Atmospheric Contaminants, 10 Year Limited Stain Warranty, Lifetime Static



# Riot

|              |  |
|--------------|--|
| Collection   | Renegade                                   |
| Style Name   | Riot                                       |
| Style Number | BT355                                      |
| Product Type | Carpet Tile                                |
| Size         | 24" X 24"                                  |
| Construction | Tufted                                     |
| Installation | Vertical Ashlar, Quarter Turn, Multi-Direc |



| Feature              | Description                                 |
|----------------------|---|
| Backing Material     | EcoFlex Matrix                              |
| Fiber Type           | ColorStrand® SD Nylon                       |
| Dye Method           | Solution Dyed                               |
| Installation Methods | Vertical Ashlar, Quarter Turn, Multi-Direct |
| Stitches per Inch    | 9.8 (38.58 per 10cm)                        |
| Density              | 5094  |
| Tufted Pile Weight   | 14.80 oz/yd2 (502 g/m2)                     |
| Surface Texture      | Textured Patterned Loop                     |

## Colorways



### Living Fast

Color code: 152  
Style number: BT355



### Thrill Seeker

Color code: 358  
Style number: BT355



### Dare Devil

Color code: 751  
Style number: BT355



### Glory Days

Color code: 859  
Style number: BT355



### Tough Guy

Color code: 862  
Style number: BT355



### Wild Thing

Color code: 883  
Style number: BT355



### Cool Hand

Color code: 955  
Style number: BT355

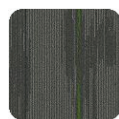

### Roust About

Color code: 983  
Style number: BT355



### Leather Jacket

Color code: 999  
Style number: BT355



## Performance

| Feature                          | Description                    |
|----------------------------------|--------------------------------|
| Gauge                            | 1/12 (47.00 rows per 10 cm)    |
| Stain Release Technology         | Pass                           |
| Foot Traffic Recommendation TARR | Severe                         |
| Flammability                     | ASTM E 648 Class 1 (Glue Down) |
| Smoke Density                    | ASTM E 662 Less than 450       |
| Static Propensity                | AATCC-134 Under 3.5 KV         |
| Soil Release Technology          | EcoSentry Soil Protection      |

## Sustainability

| Feature                         | Description  |
|---------------------------------|--|
| Beyond Carbon Neutral           | This product is 100% carbon neutral plus an additional 5% offset |
| Carbon Handprint                | -0.053 kg CO <sub>2</sub> e/ft <sup>2</sup>                      |
| Embodied Carbon                 | 1.06 kg CO <sub>2</sub> e/ft <sup>2</sup>                        |
| Total Recycled Content          | 48%  |
| Pre-Consumer Recycled Content   | 48%  |
| NSF 140                         | <a href="#">EcoFlex Matrix - NSF 140 Gold</a>                    |
| TVOC Range                      | 0.5 mg/m <sup>3</sup> or less                                    |
| Red List Free                   | True   |
| Declare Label                   | Nylon Modular Carpet on EcoFlex Matrix                           |
| Mindful Materials               | Participates in Mindful Materials Library                        |
| Take Back Program               | <a href="#">ReCover Program</a>                                  |
| Health Product Declaration      | <a href="#">HPD 2.1 EcoFlex Matrix - 1000 ppm</a>                |
| Environmental Claims Validation | <a href="#">EPD EcoFlex Matrix</a>                               |
| Global Green Tag                | GreenRate Level A, LCARate Silver Plus                           |
| LEED Credit Potential           | LEED Eligible  |

## Warranties

Lifetime Limited Carpet Tile Warranty, Lifetime Limited Colorfastness to Light, 10 Year Limited Colorfastness to Atmospheric Contaminants, 10 Year Limited Stain Warranty, Lifetime Static



# Motivated Movement

|              |   |
|--------------|---|
| Collection   | Taking Steps                                |
| Style Name   | Motivated Movement                          |
| Style Number | GT465                                       |
| Product Type | Carpet Tile                                 |
| Size         | 24" X 24"                                   |
| Construction | Tufted                                      |
| Installation | Quarter Turn, Vertical Ashlar, Brick Ashlar |

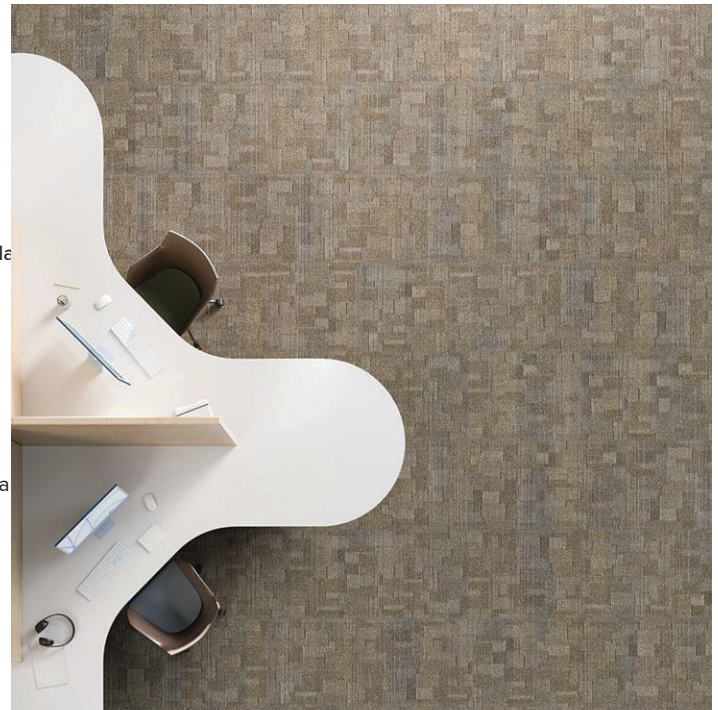

| Feature              | Description                                 |
|----------------------|---|
| Backing Material     | EcoFlex NXT                                 |
| Fiber Type           | Duracolor® Tricor Premium Nylon             |
| Dye Method           | Solution Dyed                               |
| Installation Methods | Quarter Turn, Vertical Ashlar, Brick Ashlar |
| Stitches per Inch    | 13 (51.18 per 10cm)                         |
| Density              | 6612  |
| Tufted Pile Weight   | 18.00 oz/yd2 (610 g/m2)                     |
| Surface Texture      | Textured Patterned Loop                     |

## Colorways



### Franklin

Color code: 565  
Style number: GT465



### Tennelli

Color code: 566  
Style number: GT465



### Terese

Color code: 853  
Style number: GT465



### Ramon

Color code: 855  
Style number: GT465



### LI

Color code: 858  
Style number: GT465



### Henry

Color code: 955  
Style number: GT465



### Wright

Color code: 956  
Style number: GT465



### Frizzle

Color code: 958  
Style number: GT465



### Hudson

Color code: 969  
Style number: GT465





## Performance

| Feature                          | Description                    |
|----------------------------------|--------------------------------|
| Gauge                            | 1/12 (47.00 rows per 10cm)     |
| Stain Release Technology         | Pass                           |
| Foot Traffic Recommendation TARR | Heavy                          |
| Flammability                     | ASTM E 648 Class 1 (Glue Down) |
| Smoke Density                    | ASTM E 662 Less than 450       |
| Static Propensity                | AATCC-134 Under 3.5 KV         |
| Soil Release Technology          | EcoSentry Soil Protection      |

## Sustainability

| Feature                    | Description  |
|----------------------------|--|
| Beyond Carbon Neutral      | This product is 100% carbon neutral plus an additional 5% offset |
| Carbon Handprint           | -0.062 kg CO2e/ft2   |
| Embodied Carbon            | 1.24 kg CO2e/ft2   |
| Total Recycled Content     | 51%  |
| NSF 140                    | <a href="#">EcoFlex NXT - NSF 140 Gold</a>                       |
| Indoor Air Quality         | <a href="#">GLP 1171</a>   |
| Red List Free              | True   |
| Declare Label              | Nylon Modular Carpet on EcoFlex NXT                              |
| Take Back Program          | <a href="#">ReCover Program</a>                                  |
| Health Product Declaration | <a href="#">HPD 2.1 EcoFlex NXT Gold - 1000 ppm</a>              |
| LEED Credit Potential      | LEED Eligible  |

## Warranties

Lifetime Limited Carpet Tile Warranty, Lifetime Limited Duracolor Stain Warranty, Lifetime Static



# First One Up II

|              |  |
|--------------|--|
| Style Name   | First One Up II                            |
| Style Number | BT443                                      |
| Product Type | Carpet Tile                                |
| Size         | 24" X 24"                                  |
| Construction | Tufted                                     |
| Installation | Quarter Turn, Vertical Ashlar, Brick Ashle |



| Feature              | Description                                |
|----------------------|--|
| Backing Material     | EcoFlex NXT                                |
| Fiber Type           | ColorStrand® SD Nylon                      |
| Dye Method           | Solution Dyed                              |
| Installation Methods | Quarter Turn, Vertical Ashlar, Brick Ashla |
| Stitches per Inch    | 9.73 (38.32 per 10cm)                      |
| Density              | 9000                                       |
| Tufted Pile Weight   | 22.00 oz/yd2 (746 g/m2)                    |
| Surface Texture      | Textured Patterned Loop                    |

## Colorways



### Foremost

Color code: 556  
Style number: BT443



### Priority

Color code: 727  
Style number: BT443



### Beginning

Color code: 848  
Style number: BT443



### Immediate

Color code: 869  
Style number: BT443



### Preference

Color code: 959  
Style number: BT443



### Importance

Color code: 988  
Style number: BT443

## Performance

| Feature                          | Description                    |
|----------------------------------|--------------------------------|
| Gauge                            | 1/12 (47.00 rows per 10 cm)    |
| Foot Traffic Recommendation TARR | Severe                         |
| Flammability                     | ASTM E 648 Class 1 (Glue Down) |
| Smoke Density                    | ASTM E 662 Less than 450       |
| Static Propensity                | AATCC-134 Under 3.5 KV         |
| Soil Release Technology          | EcoSentry Soil Protection      |



## Sustainability

| Feature                         | Description  |
|---------------------------------|--|
| Beyond Carbon Neutral           | This product is 100% carbon neutral plus an additional 5% offset |
| Carbon Handprint                | -0.07 kg CO2e/ft2  |
| Embodied Carbon                 | 1.41 kg CO2e/ft2   |
| Total Recycled Content          | 48%  |
| Pre-Consumer Recycled Content   | 48%  |
| NSF 140                         | <a href="#">EcoFlex NXT - NSF 140 Gold</a>                       |
| Indoor Air Quality              | GLP 1098   |
| TVOC Range                      | 0.5 mg/m3 or less  |
| Red List Free                   | True   |
| Declare Label                   | Nylon Modular Carpet on EcoFlex NXT                              |
| Mindful Materials               | Participates in Mindful Materials Library                        |
| Take Back Program               | <a href="#">ReCover Program</a>                                  |
| Health Product Declaration      | <a href="#">HPD 2.1 EcoFlex NXT Gold - 1000 ppm</a>              |
| Environmental Claims Validation | <a href="#">EPD EcoFlex NXT</a>                                  |
| Global Green Tag                | GreenRate Level A, LCARate Silver Plus                           |
| LEED Credit Potential           | LEED Eligible  |

## Warranties

Lifetime Limited Carpet Tile Warranty, Lifetime Limited Colorfastness to Light, 10 Year Colorfastness to Atmospheric Contaminants, 10 Year Stain Warranty, Lifetime Static



# Reckless

|              |  |
|--------------|--|
| Collection   | Renegade                                   |
| Style Name   | Reckless                                   |
| Style Number | BT353                                      |
| Product Type | Carpet Tile                                |
| Size         | 24" X 24"                                  |
| Construction | Tufted                                     |
| Installation | Vertical Ashlar, Quarter Turn, Multi-Direc |



| Feature              | Description                                 |
|----------------------|---|
| Backing Material     | EcoFlex Matrix                              |
| Fiber Type           | ColorStrand® SD Nylon                       |
| Dye Method           | Solution Dyed                               |
| Installation Methods | Vertical Ashlar, Quarter Turn, Multi-Direct |
| Stitches per Inch    | 9.6 (37.8 per 10cm)                         |
| Density              | 5123  |
| Tufted Pile Weight   | 14.80 oz/yd2 (502 g/m2)                     |
| Surface Texture      | Textured Patterned Loop                     |

## Colorways



### Living Fast

Color code: 152  
Style number: BT353



### Thrill Seeker

Color code: 358  
Style number: BT353



### Glory Days

Color code: 859  
Style number: BT353



### Tough Guy

Color code: 862  
Style number: BT353



### Wild Thing

Color code: 883  
Style number: BT353



### Cool Hand

Color code: 955  
Style number: BT353



### Roust About

Color code: 983  
Style number: BT353



### Leather Jacket

Color code: 999  
Style number: BT353



### Dare Devil

Color code: 751A  
Style number: BT353



## Performance

| Feature                          | Description                    |
|----------------------------------|--------------------------------|
| Gauge                            | 1/12 (47.00 rows per 10 cm)    |
| Foot Traffic Recommendation TARR | Severe                         |
| Flammability                     | ASTM E 648 Class 1 (Glue Down) |
| Smoke Density                    | ASTM E 662 Less than 450       |
| Static Propensity                | AATCC-134 Under 3.5 KV         |
| Soil Release Technology          | EcoSentry Soil Protection      |

## Sustainability

| Feature                         | Description  |
|---------------------------------|--|
| Beyond Carbon Neutral           | This product is 100% carbon neutral plus an additional 5% offset |
| Carbon Handprint                | -0.053 kg CO2e/ft2   |
| Embodied Carbon                 | 1.06 kg CO2e/ft2   |
| Total Recycled Content          | 48%  |
| Pre-Consumer Recycled Content   | 48%  |
| NSF 140                         | <a href="#">EcoFlex Matrix - NSF 140 Gold</a>                    |
| Indoor Air Quality              | GLP 1098   |
| TVOC Range                      | 0.5 mg/m3 or less  |
| Red List Free                   | True   |
| Declare Label                   | Nylon Modular Carpet on EcoFlex Matrix                           |
| Mindful Materials               | Participates in Mindful Materials Library                        |
| Take Back Program               | <a href="#">ReCover Program</a>                                  |
| Health Product Declaration      | <a href="#">HPD 2.1 EcoFlex Matrix - 1000 ppm</a>                |
| Environmental Claims Validation | <a href="#">EPD EcoFlex Matrix</a>                               |
| Global Green Tag                | GreenRate Level A, LCARate Silver Plus                           |
| LEED Credit Potential           | LEED Eligible  |

## Warranties

Lifetime Limited Carpet Tile Warranty, Lifetime Limited Colorfastness to Light, 10 Year Limited Colorfastness to Atmospheric Contaminants, 10 Year Limited Stain Warranty, Lifetime Static



# Lateral Surface

|              |  |
|--------------|--|
| Collection   | Bending Earth                              |
| Style Name   | Lateral Surface                            |
| Style Number | BT314                                      |
| Product Type | Carpet Tile                                |
| Size         | 24" X 24"                                  |
| Construction | Tufted                                     |
| Installation | Quarter Turn, Vertical Ashlar, Monolithic, |



| Feature              | Description                                |
|----------------------|--|
| Backing Material     | EcoFlex Matrix                             |
| Fiber Type           | ColorStrand® SD Nylon                      |
| Dye Method           | Solution Dyed                              |
| Installation Methods | Quarter Turn, Vertical Ashlar, Monolithic, |
| Stitches per Inch    | 11.6 (45.67 per 10cm)                      |
| Density              | 6013                                       |
| Tufted Pile Weight   | 17.00 oz/yd2 (576 g/m2)                    |
| Surface Texture      | Level Patterned Loop                       |

## Colorways



### Pumice

Color code: 7238  
Style number: BT314



### Opal

Color code: 7559  
Style number: BT314



### Marble

Color code: 7568  
Style number: BT314



### Ore

Color code: 7688  
Style number: BT314



### Chert

Color code: 7728  
Style number: BT314



### Basalt

Color code: 7879  
Style number: BT314



### Shale

Color code: 7927  
Style number: BT314



### Granite

Color code: 7948  
Style number: BT314



## Performance

| Feature                          | Description                    |
|----------------------------------|--------------------------------|
| Gauge                            | 1/12 (47.00 rows per 10 cm)    |
| Foot Traffic Recommendation TARR | Severe                         |
| Flammability                     | ASTM E 648 Class 1 (Glue Down) |
| Smoke Density                    | ASTM E 662 Less than 450       |
| Static Propensity                | AATCC-134 Under 3.5 KV         |
| Soil Release Technology          | EcoSentry Soil Protection      |

## Sustainability

| Feature                         | Description  |
|---------------------------------|--|
| Beyond Carbon Neutral           | This product is 100% carbon neutral plus an additional 5% offset |
| Carbon Handprint                | -0.053 kg CO2e/ft2   |
| Embodied Carbon                 | 1.06 kg CO2e/ft2   |
| Total Recycled Content          | 48%  |
| Pre-Consumer Recycled Content   | 48%  |
| NSF 140                         | <a href="#">EcoFlex Matrix - NSF 140 Gold</a>                    |
| Indoor Air Quality              | <a href="#">GLP 1171</a>   |
| TVOC Range                      | 0.5 mg/m3 or less  |
| Red List Free                   | True   |
| Declare Label                   | Nylon Modular Carpet on EcoFlex Matrix                           |
| Mindful Materials               | Participates in Mindful Materials Library                        |
| Take Back Program               | <a href="#">ReCover Program</a>                                  |
| Health Product Declaration      | <a href="#">HPD 2.1 EcoFlex Matrix - 1000 ppm</a>                |
| Environmental Claims Validation | <a href="#">EPD EcoFlex Matrix</a>                               |
| LEED Credit Potential           | LEED Eligible  |

## Warranties

Lifetime Limited Carpet Tile Warranty, Lifetime Limited Colorfastness to Light, 10 Year Limited Colorfastness to Atmospheric Contaminants, 10 Year Limited Stain Warranty, Lifetime Static



# Draft Point

|              |                            |
|--------------|----------------------------|
| Collection   | Art Intervention           |
| Style Name   | Draft Point                |
| Style Number | BT427                      |
| Product Type | Carpet Tile                |
| Size         | 24" X 24"                  |
| Construction | Tufted                     |
| Installation | Quarter Turn, Brick Ashlar |



| Feature              | Description                |
|----------------------|----------------------------|
| Backing Material     | EcoFlex Matrix             |
| Fiber Type           | ColorStrand® SD Nylon      |
| Dye Method           | Solution Dyed              |
| Installation Methods | Quarter Turn, Brick Ashlar |
| Stitches per Inch    | 12.2 (48.03 per 10cm)      |
| Density              | 5333                       |
| Tufted Pile Weight   | 16.00 oz/yd2 (543 g/m2)    |
| Surface Texture      | Level Patterned Loop       |

## Colorways



### Sand

Color code: 847  
Style number: BT427



### Pewter

Color code: 959  
Style number: BT427



### Iron

Color code: 979  
Style number: BT427



### Jet

Color code: 989  
Style number: BT427

## Performance

| Feature                          | Description                    |
|----------------------------------|--------------------------------|
| Gauge                            | 1/10 (39.37 rows per 10 cm)    |
| Foot Traffic Recommendation TARR | Heavy                          |
| Flammability                     | ASTM E 648 Class 1 (Glue Down) |
| Smoke Density                    | ASTM E 662 Less than 450       |
| Static Propensity                | AATCC-134 Under 3.5 KV         |
| Soil Release Technology          | EcoSentry Soil Protection      |





## Sustainability

| Feature                         | Description  |
|---------------------------------|--|
| Beyond Carbon Neutral           | This product is 100% carbon neutral plus an additional 5% offset |
| Carbon Handprint                | -0.055 kg CO2e/ft2   |
| Embodied Carbon                 | 1.1 kg CO2e/ft2  |
| Total Recycled Content          | 53%  |
| Pre-Consumer Recycled Content   | 53%  |
| NSF 140                         | <a href="#">EcoFlex Matrix - NSF 140 Gold</a>                    |
| Indoor Air Quality              | <a href="#">GLP 1171</a>   |
| TVOC Range                      | 0.5 mg/m3 or less  |
| Red List Free                   | True   |
| Declare Label                   | Nylon Modular Carpet on EcoFlex Matrix                           |
| Mindful Materials               | Participates in Mindful Materials Library                        |
| Take Back Program               | <a href="#">ReCover Program</a>                                  |
| Health Product Declaration      | <a href="#">HPD 2.1 EcoFlex Matrix - 1000 ppm</a>                |
| Environmental Claims Validation | <a href="#">EPD EcoFlex Matrix</a>                               |
| LEED Credit Potential           | LEED Eligible  |

## Warranties

Lifetime Limited Carpet Tile Warranty, Lifetime Limited Colorfastness to Light, 10 Year Colorfastness to Atmospheric Contaminants, 10 Year Stain Warranty, 10 Year Limited Static



# Headstrong

|              |  |
|--------------|--|
| Collection   | Renegade                                   |
| Style Name   | Headstrong                                 |
| Style Number | BT354                                      |
| Product Type | Carpet Tile                                |
| Size         | 24" X 24"                                  |
| Construction | Tufted                                     |
| Installation | Vertical Ashlar, Quarter Turn, Multi-Direc |



| Feature              | Description                                 |
|----------------------|---|
| Backing Material     | EcoFlex Matrix                              |
| Fiber Type           | ColorStrand® SD Nylon                       |
| Dye Method           | Solution Dyed                               |
| Installation Methods | Vertical Ashlar, Quarter Turn, Multi-Direct |
| Stitches per Inch    | 9.8 (38.58 per 10cm)                        |
| Density              | 5346  |
| Tufted Pile Weight   | 14.80 oz/yd2 (502 g/m2)                     |
| Surface Texture      | Textured Patterned Loop                     |

## Colorways



### Living Fast

Color code: 152  
Style number: BT354



### Thrill Seeker

Color code: 358  
Style number: BT354



### Dare Devil

Color code: 751  
Style number: BT354



### Glory Days

Color code: 859  
Style number: BT354



### Tough Guy

Color code: 862  
Style number: BT354



### Wild Thing

Color code: 883  
Style number: BT354



### Cool Hand

Color code: 955  
Style number: BT354



### Roust About

Color code: 983  
Style number: BT354



### Leather Jacket

Color code: 999  
Style number: BT354



## Performance

| Feature                          | Description                    |
|----------------------------------|--------------------------------|
| Gauge                            | 1/12 (47.00 rows per 10 cm)    |
| Stain Release Technology         | Pass                           |
| Foot Traffic Recommendation TARR | Severe                         |
| Flammability                     | ASTM E 648 Class 1 (Glue Down) |
| Smoke Density                    | ASTM E 662 Less than 450       |
| Static Propensity                | AATCC-134 Under 3.5 KV         |
| Soil Release Technology          | EcoSentry Soil Protection      |

## Sustainability

| Feature                         | Description  |
|---------------------------------|--|
| Beyond Carbon Neutral           | This product is 100% carbon neutral plus an additional 5% offset |
| Carbon Handprint                | -0.053 kg CO2e/ft2   |
| Embodied Carbon                 | 1.06 kg CO2e/ft2   |
| Total Recycled Content          | 48%  |
| Pre-Consumer Recycled Content   | 48%  |
| NSF 140                         | <a href="#">EcoFlex Matrix - NSF 140 Gold</a>                    |
| Indoor Air Quality              | <a href="#">GLP 1171</a>   |
| TVOC Range                      | 0.5 mg/m3 or less  |
| Red List Free                   | True   |
| Declare Label                   | Nylon Modular Carpet on EcoFlex Matrix                           |
| Mindful Materials               | Participates in Mindful Materials Library                        |
| Take Back Program               | <a href="#">ReCover Program</a>                                  |
| Health Product Declaration      | <a href="#">HPD 2.1 EcoFlex Matrix - 1000 ppm</a>                |
| Environmental Claims Validation | <a href="#">EPD EcoFlex Matrix</a>                               |
| Global Green Tag                | GreenRate Level A, LCARate Silver Plus                           |
| LEED Credit Potential           | LEED Eligible  |

## Warranties

Lifetime Limited Carpet Tile Warranty, Lifetime Limited Colorfastness to Light, 10 Year Limited Colorfastness to Atmospheric Contaminants, 10 Year Limited Stain Warranty, Lifetime Static



# X-Factor

|              |  |
|--------------|--|
| Style Name   | X-Factor                               |
| Style Number | BT212                                  |
| Product Type | Carpet Tile                            |
| Size         | 24" X 24"                              |
| Construction | Tufted                                 |
| Installation | Brick Ashlar, Monolithic, Quarter Turn |



| Feature              | Description                            |
|----------------------|--|
| Backing Material     | EcoFlex Matrix                         |
| Fiber Type           | ColorStrand® SD Nylon                  |
| Dye Method           | Solution Dyed                          |
| Installation Methods | Brick Ashlar, Monolithic, Quarter Turn |
| Stitches per Inch    | 12 (47.24 per 10cm)                    |
| Density              | 4037                                   |
| Tufted Pile Weight   | 12.00 oz/yd2 (407 g/m2)                |
| Surface Texture      | Level Patterned Loop                   |

## Colorways



### Secret Agent

Color code: 7558  
Style number: BT212



### Cloak & Dagger

Color code: 7589  
Style number: BT212



### Hush Hush

Color code: 7638  
Style number: BT212



### Disguise

Color code: 7877  
Style number: BT212



### Undercover

Color code: 7889  
Style number: BT212



### Incognito

Color code: 7936  
Style number: BT212



### Confidential

Color code: 7979  
Style number: BT212



## Performance

| Feature                          | Description                    |
|----------------------------------|--------------------------------|
| Gauge                            | 1/10 (39.37 rows per 10 cm)    |
| Foot Traffic Recommendation TARR | Severe                         |
| Flammability                     | ASTM E 648 Class 1 (Glue Down) |
| Smoke Density                    | ASTM E 662 Less than 450       |
| Static Propensity                | AATCC-134 Under 3.5 KV         |
| Soil Release Technology          | EcoSentry Soil Protection      |

## Sustainability

| Feature                         | Description  |
|---------------------------------|--|
| Beyond Carbon Neutral           | This product is 100% carbon neutral plus an additional 5% offset |
| Carbon Handprint                | -0.051 kg CO2e/ft2   |
| Embodied Carbon                 | 1.02 kg CO2e/ft2   |
| Total Recycled Content          | 48%  |
| Pre-Consumer Recycled Content   | 48%  |
| NSF 140                         | <a href="#">EcoFlex Matrix - NSF 140 Gold</a>                    |
| Indoor Air Quality              | <a href="#">GLP 1171</a>   |
| TVOC Range                      | 0.5 mg/m3 or less  |
| Red List Free                   | True   |
| Declare Label                   | Nylon Modular Carpet on EcoFlex Matrix                           |
| Mindful Materials               | Participates in Mindful Materials Library                        |
| Take Back Program               | <a href="#">ReCover Program</a>                                  |
| Health Product Declaration      | <a href="#">HPD 2.1 EcoFlex Matrix - 1000 ppm</a>                |
| Environmental Claims Validation | <a href="#">EPD EcoFlex Matrix</a>                               |
| Global Green Tag                | GreenRate Level A, LCARate Silver Plus                           |
| LEED Credit Potential           | LEED Eligible  |

## Warranties

Lifetime Limited Carpet Tile Warranty, Lifetime Limited Colorfastness to Light, 10 Year Limited Colorfastness to Atmospheric Contaminants, 10 Year Limited Stain Warranty, Lifetime Static



# Chitalpa

|              |   |
|--------------|---|
| Collection   | Healthy Environments                        |
| Style Name   | Chitalpa                                    |
| Style Number | GT407                                       |
| Product Type | Carpet Tile                                 |
| Size         | 12" X 36"                                   |
| Construction | Tufted                                      |
| Installation | Half Lap, Brick Ashlar, Random, Herringbone |



| Feature              | Description                                      |
|----------------------|--|
| Backing Material     | EcoFlex NXT                                      |
| Fiber Type           | Duracolor® Tricor Premium Nylon                  |
| Dye Method           | Solution Dyed                                    |
| Installation Methods | Half Lap, Brick Ashlar, Random, Herringbone      |
| Stitches per Inch    | 12 (47.24 per 10cm)                              |
| Density              | 8425   |
| Tufted Pile Weight   | 22.00 oz/yd <sup>2</sup> (746 g/m <sup>2</sup> ) |
| Surface Texture      | Textured Patterned Loop                          |

## Colorways



### Acoma

Color code: 867  
Style number: GT407



### Hopi

Color code: 877  
Style number: GT407



### Cholla

Color code: 947  
Style number: GT407



### Acacia

Color code: 951  
Style number: GT407



### Moapa

Color code: 952  
Style number: GT407



### Larkspur

Color code: 955  
Style number: GT407



### Pinyon

Color code: 956  
Style number: GT407



### Mesa

Color code: 957  
Style number: GT407



### Kofa

Color code: 959  
Style number: GT407



### Zuni

Color code: 993  
Style number: GT407



## Performance

| Feature                          | Description                    |
|----------------------------------|--------------------------------|
| Gauge                            | 1/12 (47.00 rows per 10 cm)    |
| Stain Release Technology         | Pass                           |
| Foot Traffic Recommendation TARR | Severe                         |
| Flammability                     | ASTM E 648 Class 1 (Glue Down) |
| Smoke Density                    | ASTM E 662 Less than 450       |
| Static Propensity                | AATCC-134 Under 3.5 KV         |
| Soil Release Technology          | EcoSentry Soil Treatment       |

## Sustainability

| Feature                         | Description  |
|---------------------------------|--|
| Beyond Carbon Neutral           | This product is 100% carbon neutral plus an additional 5% offset |
| Carbon Handprint                | -0.07 kg CO2e/ft2  |
| Embodied Carbon                 | 1.41 kg CO2e/ft2   |
| Total Recycled Content          | 57%  |
| Pre-Consumer Recycled Content   | 57%  |
| NSF 140                         | <a href="#">EcoFlex NXT - NSF 140 Gold</a>                       |
| Indoor Air Quality              | <a href="#">GLP 1171</a>   |
| TVOC Range                      | 0.5 mg/m3 or less  |
| Red List Free                   | True   |
| Declare Label                   | Nylon Modular Carpet on EcoFlex NXT                              |
| Mindful Materials               | Participates in Mindful Materials Library                        |
| Take Back Program               | <a href="#">ReCover Program</a>                                  |
| Health Product Declaration      | <a href="#">HPD 2.1 EcoFlex NXT Gold - 1000 ppm</a>              |
| Environmental Claims Validation | <a href="#">EPD EcoFlex NXT</a>                                  |
| Global Green Tag                | GreenRate Level A, LCARate Silver Plus                           |
| LEED Credit Potential           | LEED Eligible  |

## Warranties

Lifetime Limited Carpet Tile Warranty, Lifetime Duracolor Stain Warranty, Lifetime Static



# Biome

|              |                                       |
|--------------|---------------------------------------|
| Collection   | Data Tide                             |
| Style Name   | Biome                                 |
| Style Number | GT456                                 |
| Product Type | Carpet Tile                           |
| Size         | 12" X 36"                             |
| Construction | Tufted                                |
| Installation | Herringbone, Basket Weave, Monolithic |



| Feature              | Description                                      |
|----------------------|--|
| Backing Material     | EcoFlex NXT                                      |
| Fiber Type           | Duracolor® Tricor Premium Nylon                  |
| Dye Method           | Solution Dyed                                    |
| Installation Methods | Herringbone, Basket Weave, Monolithic            |
| Stitches per Inch    | 10.2 (40.16 per 10cm)                            |
| Density              | 6923   |
| Tufted Pile Weight   | 20.00 oz/yd <sup>2</sup> (678 g/m <sup>2</sup> ) |
| Surface Texture      | Textured Patterned Multi-Colored Loop            |

## Colorways



### Wetland

Color code: 549  
Style number: GT456



### Freshwater

Color code: 558  
Style number: GT456



### Blue Carbon

Color code: 575  
Style number: GT456



### Saltmarsh

Color code: 748  
Style number: GT456



### Brackish

Color code: 759  
Style number: GT456



### Delta

Color code: 859  
Style number: GT456



### Coastline

Color code: 947  
Style number: GT456



### Sediment

Color code: 979  
Style number: GT456





## Performance

| Feature                          | Description                    |
|----------------------------------|--------------------------------|
| Gauge                            | 1/12 (47.00 rows per 10 cm)    |
| Stain Release Technology         | Pass                           |
| Foot Traffic Recommendation TARR | Heavy                          |
| Flammability                     | ASTM E 648 Class 1 (Glue Down) |
| Smoke Density                    | ASTM E 662 Less than 450       |
| Static Propensity                | AATCC-134 Under 3.5 KV         |
| Soil Release Technology          | EcoSentry Soil Protection      |

## Sustainability

| Feature                         | Description  |
|---------------------------------|--|
| Beyond Carbon Neutral           | This product is 100% carbon neutral plus an additional 5% offset |
| Carbon Handprint                | -0.066 kg CO <sub>2</sub> e/ft <sup>2</sup>                      |
| Embodied Carbon                 | 1.33 kg CO <sub>2</sub> e/ft <sup>2</sup>                        |
| NSF 140                         | <a href="#">EcoFlex NXT - NSF 140 Gold</a>                       |
| Indoor Air Quality              | <a href="#">GLP 1171</a>   |
| TVOC Range                      | 0.5 mg/m <sup>3</sup> or less                                    |
| Red List Free                   | True   |
| Declare Label                   | Nylon Modular Carpet on EcoFlex NXT                              |
| Mindful Materials               | Participates in Mindful Materials Library                        |
| Take Back Program               | <a href="#">ReCover Program</a>                                  |
| Health Product Declaration      | <a href="#">HPD 2.1 EcoFlex NXT Gold - 1000 ppm</a>              |
| Environmental Claims Validation | <a href="#">EPD EcoFlex NXT</a>                                  |
| Global Green Tag                | GreenRate Level A, LCARate Silver Plus                           |
| LEED Credit Potential           | LEED Eligible  |

## Warranties

Lifetime Limited Carpet Tile Warranty, Lifetime Limited Duracolor Stain Warranty, Lifetime Static



# Metallic Path

|              |  |
|--------------|--|
| Collection   | Art Style                                  |
| Style Name   | Metallic Path                              |
| Style Number | BT431                                      |
| Product Type | Carpet Tile                                |
| Size         | 12" X 36"                                  |
| Construction | Tufted                                     |
| Installation | Monolithic, Half Lap, Brick Ashlar, Basket |



| Feature              | Description                                |
|----------------------|--|
| Backing Material     | EcoFlex NXT                                |
| Fiber Type           | ColorStrand® SD Nylon                      |
| Dye Method           | Solution Dyed                              |
| Installation Methods | Monolithic, Half Lap, Brick Ashlar, Basket |
| Stitches per Inch    | 12 (47.24 per 10cm)                        |
| Density              | 7846                                       |
| Tufted Pile Weight   | 17.00 oz/yd2 (576 g/m2)                    |
| Surface Texture      | Level Multi-Colored Patterned Loop         |

## Colorways

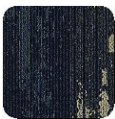

### Cadet Blaze

Color code: 559  
Style number: BT431



### Fallow Reflection

Color code: 859  
Style number: BT431



### Platinum Gleam

Color code: 929  
Style number: BT431



### Ecru Glimmer

Color code: 939  
Style number: BT431



### Slate Burst

Color code: 949  
Style number: BT431



### Charcoal Spark

Color code: 979  
Style number: BT431

## Performance

| Feature                          | Description                    |
|----------------------------------|--------------------------------|
| Gauge                            | 1/12 (47.00 rows per 10 cm)    |
| Foot Traffic Recommendation TARR | Severe                         |
| Flammability                     | ASTM E 648 Class 1 (Glue Down) |
| Smoke Density                    | ASTM E 662 Less than 450       |
| Static Propensity                | AATCC-134 Under 3.5 KV         |
| Soil Release Technology          | EcoSentry Soil Protection      |



## Sustainability

| Feature                         | Description  |
|---------------------------------|--|
| Beyond Carbon Neutral           | This product is 100% carbon neutral plus an additional 5% offset |
| Carbon Handprint                | -0.06 kg CO2e/ft2  |
| Embodied Carbon                 | 1.2 kg CO2e/ft2  |
| Total Recycled Content          | 61%  |
| Pre-Consumer Recycled Content   | 61%  |
| NSF 140                         | <a href="#">EcoFlex NXT - NSF 140 Gold</a>                       |
| Indoor Air Quality              | <a href="#">GLP 1171</a>   |
| TVOC Range                      | 0.5 mg/m3 or less  |
| Red List Free                   | True   |
| Declare Label                   | Nylon Modular Carpet on EcoFlex NXT                              |
| Mindful Materials               | Participates in Mindful Materials Library                        |
| Take Back Program               | <a href="#">ReCover Program</a>                                  |
| Health Product Declaration      | <a href="#">HPD 2.1 EcoFlex NXT Gold - 1000 ppm</a>              |
| Environmental Claims Validation | <a href="#">EPD EcoFlex NXT</a>                                  |
| Global Green Tag                | GreenRate Level A, LCARate Silver Plus                           |
| LEED Credit Potential           | LEED Eligible  |

## Warranties

Lifetime Limited Carpet Tile Warranty, Lifetime Limited Colorfastness to Light, 10 Year Colorfastness to Atmospheric Contaminants, 10 Year Stain Warranty, Lifetime Static



# LineD

|              |   |
|--------------|---|
| Collection   | Fractal Fluency                                 |
| Style Name   | LineD   |
| Style Number | GT477   |
| Product Type | Carpet Tile                                     |
| Size         | 12" X 36"                                       |
| Construction | Tufted  |
| Installation | Monolithic, Half Lap, Brick Ashlar, Basketweave |



| Feature              | Description                                     |
|----------------------|---|
| Backing Material     | EcoFlex ONE                                     |
| Fiber Type           | Duracolor® Tricor Premium Nylon                 |
| Dye Method           | Solution Dyed                                   |
| Installation Methods | Monolithic, Half Lap, Brick Ashlar, Basketweave |
| Stitches per Inch    | 12 (47.24 per 10cm)                             |
| Density              | 5445  |
| Tufted Pile Weight   | 18.00 oz/yd2 (610 g/m2)                         |
| Surface Texture      | Level Patterned Loop                            |

## Colorways

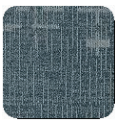

### Cornflower

Color code: 535  
Style number: GT477

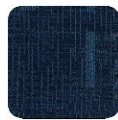

### Royal

Color code: 545  
Style number: GT477



### Flax

Color code: 839  
Style number: GT477



### Taupe

Color code: 859  
Style number: GT477



### Silver

Color code: 929  
Style number: GT477



### Mineral

Color code: 949  
Style number: GT477



### Iron

Color code: 969  
Style number: GT477



### Charcoal

Color code: 989  
Style number: GT477



## Performance

| Feature                  | Description                    |
|--------------------------|--------------------------------|
| Gauge                    | 1/12 (47.00 rows per 10 cm)    |
| Stain Release Technology | Pass                           |
| Flammability             | ASTM E 648 Class 1 (Glue Down) |
| Smoke Density            | ASTM E 662 Less than 450       |
| Static Propensity        | AATCC - 134 Under 3.5 KV       |
| Soil Release Technology  | EcoSentry Soil Protection      |

## Sustainability

| Feature                         | Description  |
|---------------------------------|--|
| Beyond Carbon Neutral           | This product is 100% carbon neutral plus an additional 5% offset |
| Carbon Handprint                | -0.03 kg CO2e/ft2  |
| Embodied Carbon                 | 0.61 kg CO2e/ft2   |
| NSF 140                         | EcoFlex One - NSF 140 Platinum                                   |
| Indoor Air Quality              | <a href="#">GLP 1171</a>   |
| Red List Free                   | True   |
| Declare Label                   | Nylon Modular Carpet on EcoFlex ONE Backing                      |
| Environmental Claims Validation | EPD EcoFlex One  |
| Global Green Tag                | Green Label Plus Certified # 1171                                |

## Warranties

Lifetime Limited Carpet Tile Warranty, Lifetime Limited Duracolor Stain Warranty, Lifetime Static, Lifetime Static



# Proficient

|              |   |
|--------------|---|
| Collection   | Learn and Live                            |
| Style Name   | Proficient                                |
| Style Number | GT432                                     |
| Product Type | Carpet Tile                               |
| Size         | 12" X 36"                                 |
| Construction | Tufted                                    |
| Installation | Half Lap, Brick Ashlar, Basket Weave, Pla |



| Feature              | Description                               |
|----------------------|---|
| Overall Thickness    | .255" (6.48 mm)                           |
| Backing Material     | EcoFlex NXT                               |
| Fiber Type           | Duracolor® Tricor Premium Nylon           |
| Dye Method           | Solution Dyed                             |
| Installation Methods | Half Lap, Brick Ashlar, Basket Weave, Pla |
| Stitches per Inch    | 11.5 (45.28 per 10cm)                     |
| Density              | 5614                                      |
| Tufted Pile Weight   | 17.00 oz/yd2 (576 g/m2)                   |
| Surface Texture      | Level Heathered Loop                      |

## Colorways



### Syllabus

Color code: 562  
Style number: GT432



### Quarter

Color code: 564  
Style number: GT432



### Advisor

Color code: 566  
Style number: GT432



### Pre-Req

Color code: 853  
Style number: GT432



### Commencement

Color code: 854  
Style number: GT432



### Credit Hour

Color code: 859  
Style number: GT432



### Term

Color code: 961  
Style number: GT432



### Gen Ed

Color code: 962  
Style number: GT432



### Lecture

Color code: 963  
Style number: GT432



## Performance

| Feature                          | Description                    |
|----------------------------------|--------------------------------|
| Gauge                            | 1/12 (47.00 rows per 10 cm)    |
| Stain Release Technology         | Pass                           |
| Foot Traffic Recommendation TARR | Severe                         |
| Flammability                     | ASTM E 648 Class 1 (Glue Down) |
| Smoke Density                    | ASTM E 662 Less than 450       |
| Static Propensity                | AATCC-134 Under 3.5 KV         |
| Soil Release Technology          | EcoSentry Soil Protection      |

## Sustainability

| Feature                         | Description  |
|---------------------------------|--|
| Beyond Carbon Neutral           | This product is 100% carbon neutral plus an additional 5% offset |
| Carbon Handprint                | -0.06 kg CO <sub>2</sub> e/ft <sup>2</sup>                       |
| Embodied Carbon                 | 1.2 kg CO <sub>2</sub> e/ft <sup>2</sup>                         |
| Total Recycled Content          | 60%  |
| Pre-Consumer Recycled Content   | 60%  |
| NSF 140                         | <a href="#">EcoFlex NXT - NSF 140 Gold</a>                       |
| Indoor Air Quality              | GPL 1171   |
| TVOC Range                      | 0.5 mg/m <sup>3</sup> or less                                    |
| Red List Free                   | True   |
| Declare Label                   | Nylon Modular Carpet on EcoFlex NXT                              |
| Mindful Materials               | Participates in Mindful Materials Library                        |
| Take Back Program               | <a href="#">ReCover Program</a>                                  |
| Health Product Declaration      | <a href="#">HPD 2.1 EcoFlex NXT Gold - 1000 ppm</a>              |
| Environmental Claims Validation | <a href="#">EPD EcoFlex NXT</a>                                  |
| Global Green Tag                | GreenRate Level A, LCARate Silver Plus                           |
| LEED Credit Potential           | LEED Eligible  |

## Warranties

Lifetime Limited Carpet Tile Warranty, Lifetime Limited Duracolor Stain Warranty, Lifetime Static



# Digital Terrain

|              |  |
|--------------|--|
| Collection   | Expedition                                 |
| Style Name   | Digital Terrain                            |
| Style Number | GT341                                      |
| Product Type | Carpet Tile                                |
| Size         | 12" X 36"                                  |
| Construction | Tufted                                     |
| Installation | Monolithic, Half Lap, Brick Ashlar, Basket |

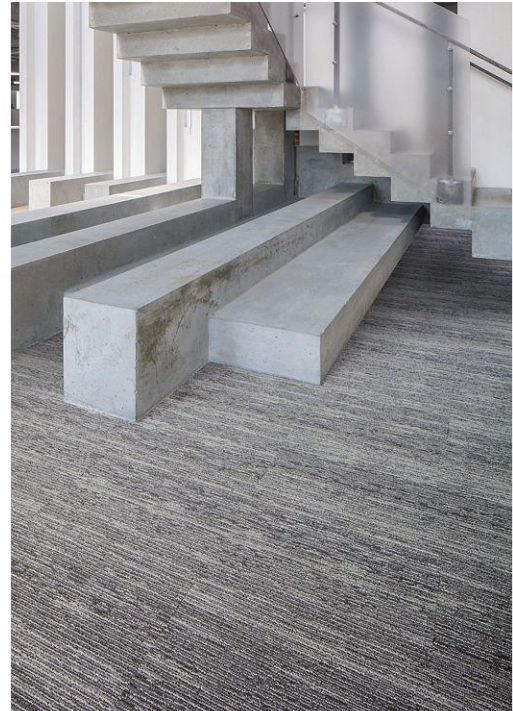

| Feature              | Description                                |
|----------------------|--|
| Backing Material     | Ecoflex Nxt                                |
| Fiber Type           | Duracolor® Tricor Premium Nylon with m     |
| Dye Method           | Solution Dyed                              |
| Installation Methods | Monolithic, Half Lap, Brick Ashlar, Basket |
| Stitches per Inch    | 10.5 (41.34 per 10cm)                      |
| Density              | 8571                                       |
| Tufted Pile Weight   | 20.00 oz/yd2 (678 g/m2)                    |
| Surface Texture      | Textured Patterned Loop                    |

## Colorways



### Sulpher

Color code: 138  
Style number: GT341



### Lagoon

Color code: 576  
Style number: GT341



### Glacier

Color code: 739  
Style number: GT341



### Sediment

Color code: 856  
Style number: GT341



### Alpine

Color code: 869  
Style number: GT341



### Fossil

Color code: 949  
Style number: GT341



### Coastal

Color code: 955  
Style number: GT341



### Mineral

Color code: 978  
Style number: GT341





## Performance

| Feature                          | Description                    |
|----------------------------------|--------------------------------|
| Gauge                            | 1/12 (47.00 rows per 10 cm)    |
| Stain Release Technology         | Pass                           |
| Foot Traffic Recommendation TARR | Severe                         |
| Flammability                     | ASTM E 648 Class 1 (Glue Down) |
| Smoke Density                    | ASTM E 662 Less than 450       |
| Static Propensity                | AATCC-134 Under 3.5 KV         |
| Soil Release Technology          | EcoSentry Soil Protection      |

## Sustainability

| Feature                         | Description  |
|---------------------------------|--|
| Beyond Carbon Neutral           | This product is 100% carbon neutral plus an additional 5% offset |
| Carbon Handprint                | -0.066 kg CO <sub>2</sub> e/ft <sup>2</sup>                      |
| Embodied Carbon                 | 1.33 kg CO <sub>2</sub> e/ft <sup>2</sup>                        |
| Total Recycled Content          | 56%  |
| Pre-Consumer Recycled Content   | 56%  |
| NSF 140                         | <a href="#">EcoFlex NXT - NSF 140 Gold</a>                       |
| Indoor Air Quality              | <a href="#">GLP 1171</a>   |
| TVOC Range                      | 0.5 mg/m <sup>3</sup> or less                                    |
| Red List Free                   | True   |
| Declare Label                   | Nylon Modular Carpet on EcoFlex NXT                              |
| Mindful Materials               | Participates in Mindful Materials Library                        |
| Take Back Program               | <a href="#">ReCover Program</a>                                  |
| Health Product Declaration      | <a href="#">HPD 2.1 EcoFlex NXT Gold - 1000 ppm</a>              |
| Environmental Claims Validation | <a href="#">EPD EcoFlex NXT</a>                                  |
| Global Green Tag                | GreenRate Level A, LCARate Silver Plus                           |
| LEED Credit Potential           | LEED Eligible  |

## Warranties

Lifetime Limited Carpet Tile Warranty, Lifetime Duracolor Stain Warranty, Lifetime Static



# SquareD

|              |  |
|--------------|--|
| Collection   | Fractal Fluency                            |
| Style Name   | SquareD                                    |
| Style Number | GT478                                      |
| Product Type | Carpet Tile                                |
| Size         | 12" X 36"                                  |
| Construction | Tufted                                     |
| Installation | Monolithic, Half Lap, Brick Ashlar, Basket |



| Feature              | Description                                |
|----------------------|--|
| Backing Material     | EcoFlex ONE                                |
| Fiber Type           | Duracolor® Tricor Premium Nylon            |
| Dye Method           | Solution Dyed                              |
| Installation Methods | Monolithic, Half Lap, Brick Ashlar, Basket |
| Stitches per Inch    | 12 (47.24 per 10cm)                        |
| Density              | 5184                                       |
| Tufted Pile Weight   | 18.00 oz/yd2 (610 g/m2)                    |
| Surface Texture      | Level Patterned Loop                       |

## Colorways



### Cornflower

Color code: 535  
Style number: GT478



### Royal

Color code: 545  
Style number: GT478



### Flax

Color code: 839  
Style number: GT478



### Taupe

Color code: 859  
Style number: GT478



### Silver

Color code: 929  
Style number: GT478



### Mineral

Color code: 949  
Style number: GT478



### Iron

Color code: 969  
Style number: GT478

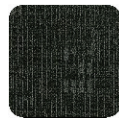

### Charcoal

Color code: 989  
Style number: GT478



## Performance

| Feature                  | Description                    |
|--------------------------|--------------------------------|
| Gauge                    | 1/12 (47.00 rows per 10 cm)    |
| Stain Release Technology | Pass                           |
| Flammability             | ASTM E 648 Class 1 (Glue Down) |
| Smoke Density            | ASTM E 662 Less than 450       |
| Static Propensity        | AATCC - 134 Under 3.5 KV       |
| Soil Release Technology  | EcoSentry Soil Protection      |

## Sustainability

| Feature                         | Description  |
|---------------------------------|--|
| Beyond Carbon Neutral           | This product is 100% carbon neutral plus an additional 5% offset |
| Carbon Handprint                | -0.03 kg CO <sub>2</sub> e/ft <sup>2</sup>                       |
| Embodied Carbon                 | 0.61 kg CO <sub>2</sub> e/ft <sup>2</sup>                        |
| NSF 140                         | EcoFlex One - NSF 140 Platinum                                   |
| Indoor Air Quality              | <a href="#">GLP 1171</a>   |
| Red List Free                   | True   |
| Declare Label                   | Nylon Modular Carpet on EcoFlex ONE Backing                      |
| Environmental Claims Validation | EPD EcoFlex One  |
| Global Green Tag                | Green Label Plus Certified # 1171                                |

## Warranties

Lifetime Limited Carpet Tile Warranty, Lifetime Limited Duracolor Stain Warranty, Lifetime Static, Lifetime Static



# Seismic Wave

|              |  |
|--------------|--|
| Collection   | Expedition                                 |
| Style Name   | Seismic Wave                               |
| Style Number | GT342                                      |
| Product Type | Carpet Tile                                |
| Size         | 12" X 36"                                  |
| Construction | Tufted                                     |
| Installation | Monolithic, Half Lap, Brick Ashlar, Basket |



| Feature              | Description                                |
|----------------------|--|
| Backing Material     | EcoFlex NXT                                |
| Fiber Type           | Duracolor® Tricolor Premium Nylon with m   |
| Dye Method           | Solution Dyed                              |
| Installation Methods | Monolithic, Half Lap, Brick Ashlar, Basket |
| Stitches per Inch    | 10.5 (41.34 per 10cm)                      |
| Density              | 7741                                       |
| Tufted Pile Weight   | 20.00 oz/yd2 (678 g/m2)                    |
| Surface Texture      | Textured Patterned Loop                    |

## Colorways



### Sulpher

Color code: 138  
Style number: GT342



### Lagoon

Color code: 576  
Style number: GT342



### Glacier

Color code: 739  
Style number: GT342



### Sediment

Color code: 856  
Style number: GT342



### Alpine

Color code: 869  
Style number: GT342



### Fossil

Color code: 949  
Style number: GT342



### Coastal

Color code: 955  
Style number: GT342



### Mineral

Color code: 978  
Style number: GT342



## Performance

| Feature                          | Description                    |
|----------------------------------|--------------------------------|
| Gauge                            | 1/12 (47.00 rows per 10 cm)    |
| Stain Release Technology         | Pass                           |
| Foot Traffic Recommendation TARR | Severe                         |
| Flammability                     | ASTM E 648 Class 1 (Glue Down) |
| Smoke Density                    | ASTM E 662 Less than 450       |
| Static Propensity                | AATCC-134 Under 3.5 KV         |
| Soil Release Technology          | EcoSentry Soil Protection      |

## Sustainability

| Feature                         | Description  |
|---------------------------------|--|
| Beyond Carbon Neutral           | This product is 100% carbon neutral plus an additional 5% offset |
| Carbon Handprint                | -0.066 kg CO2e/ft2   |
| Embodied Carbon                 | 1.33 kg CO2e/ft2   |
| Total Recycled Content          | 56%  |
| Pre-Consumer Recycled Content   | 56%  |
| NSF 140                         | <a href="#">EcoFlex NXT - NSF 140 Gold</a>                       |
| Indoor Air Quality              | <a href="#">GLP 1171</a>   |
| TVOC Range                      | 0.5 mg/m3 or less  |
| Red List Free                   | True   |
| Declare Label                   | Nylon Modular Carpet on EcoFlex NXT                              |
| Mindful Materials               | Participates in Mindful Materials Library                        |
| Take Back Program               | <a href="#">ReCover Program</a>                                  |
| Health Product Declaration      | <a href="#">HPD 2.1 EcoFlex NXT Gold - 1000 ppm</a>              |
| Environmental Claims Validation | <a href="#">EPD EcoFlex NXT</a>                                  |
| Global Green Tag                | GreenRate Level A, LCARate Silver Plus                           |
| LEED Credit Potential           | LEED Eligible  |

## Warranties

Lifetime Limited Carpet Tile Warranty, Lifetime Duracolor Stain Warranty, Lifetime Static



# Kinesthetic

|              |  |
|--------------|--|
| Collection   | Get Smart                                  |
| Style Name   | Kinesthetic                                |
| Style Number | GT317                                      |
| Product Type | Carpet Tile                                |
| Size         | 12" X 36"                                  |
| Construction | Tufted                                     |
| Installation | Monolithic, Half Lap, Brick Ashlar, Basket |

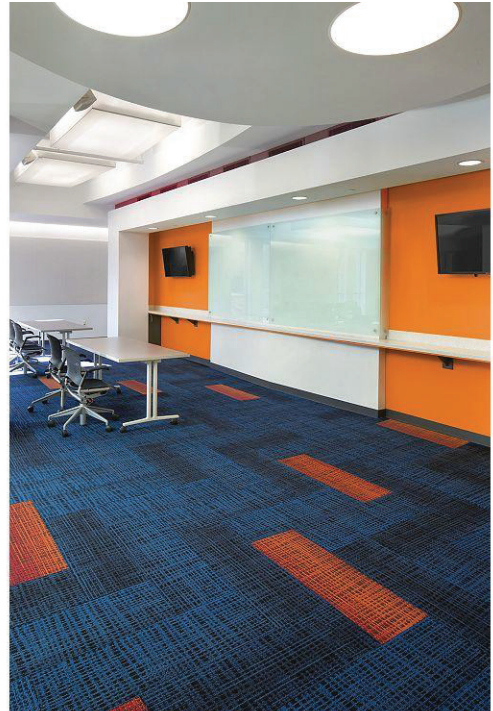

| Feature              | Description                                |
|----------------------|--|
| Backing Material     | Ecoflex Nxt                                |
| Fiber Type           | Duracolor® Tricor Premium Nylon            |
| Dye Method           | Solution Dyed                              |
| Installation Methods | Monolithic, Half Lap, Brick Ashlar, Basket |
| Stitches per Inch    | 11 (43.31 per 10cm)                        |
| Density              | 6821                                       |
| Tufted Pile Weight   | 18.00 oz/yd2 (610 g/m2)                    |
| Surface Texture      | Textured Patterned Loop                    |

## Colorways



### Cayenne

Color code: 263  
Style number: GT317

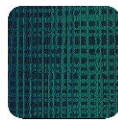

### Peacock

Color code: 566  
Style number: GT317



### Magic

Color code: 589  
Style number: GT317

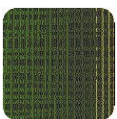

### Greenery

Color code: 661  
Style number: GT317



### Hound

Color code: 849  
Style number: GT317



### Subtle

Color code: 861  
Style number: GT317



### Everglade

Color code: 949  
Style number: GT317



### Metro

Color code: 957  
Style number: GT317



### Cocoa

Color code: 969  
Style number: GT317



### Mystic

Color code: 989  
Style number: GT317



## Performance

| Feature                          | Description                    |
|----------------------------------|--------------------------------|
| Gauge                            | 1/12 (47.00 rows per 10 cm)    |
| Stain Release Technology         | Pass                           |
| Foot Traffic Recommendation TARR | Severe                         |
| Flammability                     | ASTM E 648 Class 1 (Glue Down) |
| Smoke Density                    | ASTM E 662 Less than 450       |
| Static Propensity                | AATCC-134 Under 3.5 KV         |
| Soil Release Technology          | EcoSentry Soil Protection      |

## Sustainability

| Feature                         | Description  |
|---------------------------------|--|
| Beyond Carbon Neutral           | This product is 100% carbon neutral plus an additional 5% offset |
| Carbon Handprint                | -0.062 kg CO2e/ft2   |
| Embodied Carbon                 | 1.24 kg CO2e/ft2   |
| Total Recycled Content          | 57%  |
| Pre-Consumer Recycled Content   | 57%  |
| NSF 140                         | <a href="#">EcoFlex NXT - NSF 140 Gold</a>                       |
| Indoor Air Quality              | <a href="#">GLP 1171</a>   |
| TVOC Range                      | 0.5 mg/m3 or less  |
| Red List Free                   | True   |
| Declare Label                   | Nylon Modular Carpet on EcoFlex NXT                              |
| Mindful Materials               | Participates in Mindful Materials Library                        |
| Take Back Program               | <a href="#">ReCover Program</a>                                  |
| Health Product Declaration      | <a href="#">HPD 2.1 EcoFlex NXT Gold - 1000 ppm</a>              |
| Environmental Claims Validation | <a href="#">EPD EcoFlex NXT</a>                                  |
| Global Green Tag                | GreenRate Level A, LCARate Silver Plus                           |
| LEED Credit Potential           | LEED Eligible  |

## Warranties

Lifetime Limited Carpet Tile Warranty, Lifetime Duracolor Stain Warranty, Lifetime Static



# Hyper Earth

|              |  |
|--------------|--|
| Style Name   | Hyper Earth                                |
| Style Number | BT405                                      |
| Product Type | Carpet Tile                                |
| Size         | 12" X 36"                                  |
| Construction | Tufted                                     |
| Installation | Monolithic, Half Lap, Brick Ashlar, Basket |



| Feature              | Description                                |
|----------------------|--|
| Backing Material     | EcoFlex NXT                                |
| Fiber Type           | ColorStrand® SD Nylon                      |
| Dye Method           | Solution Dyed                              |
| Installation Methods | Monolithic, Half Lap, Brick Ashlar, Basket |
| Stitches per Inch    | 10 (39.37 per 10cm)                        |
| Density              | 6620                                       |
| Tufted Pile Weight   | 16.20 oz/yd2 (549 g/m2)                    |
| Surface Texture      | Textured Patterned loop                    |

## Colorways

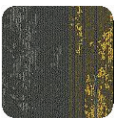

### Yellow Pyrite

Color code: 981  
Style number: BT405

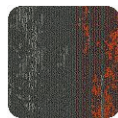

### Orange Citrine

Color code: 982  
Style number: BT405

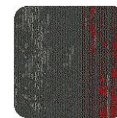

### Red Garnet

Color code: 983  
Style number: BT405



### Purple Amethyst

Color code: 984  
Style number: BT405



### Blue Sapphire

Color code: 985  
Style number: BT405

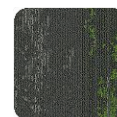

### Green Peridot

Color code: 986  
Style number: BT405

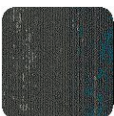

### Ice Topaz

Color code: 987  
Style number: BT405



### Pink Quartz

Color code: 988  
Style number: BT405





## Performance

| Feature                          | Description                    |
|----------------------------------|--------------------------------|
| Gauge                            | 1/12 (47.00 rows per 10 cm)    |
| Foot Traffic Recommendation TARR | Heavy                          |
| Flammability                     | ASTM E 648 Class 1 (Glue Down) |
| Smoke Density                    | ASTM E 662 Less than 450       |
| Static Propensity                | AATCC-134 Under 3.5 KV         |
| Soil Release Technology          | EcoSentry Soil Protection      |

## Sustainability

| Feature                         | Description  |
|---------------------------------|--|
| Beyond Carbon Neutral           | This product is 100% carbon neutral plus an additional 5% offset |
| Carbon Handprint                | -0.058 kg CO2e/ft2   |
| Embodied Carbon                 | 1.16 kg CO2e/ft2   |
| Total Recycled Content          | 48%  |
| Pre-Consumer Recycled Content   | 48%  |
| NSF 140                         | <a href="#">EcoFlex NXT - NSF 140 Gold</a>                       |
| Indoor Air Quality              | <a href="#">GLP 1171</a>   |
| TVOC Range                      | 0.5 mg/m3 or less  |
| Red List Free                   | True   |
| Declare Label                   | Nylon Modular Carpet on EcoFlex NXT                              |
| Mindful Materials               | Participates in Mindful Materials Library                        |
| Take Back Program               | <a href="#">ReCover Program</a>                                  |
| Health Product Declaration      | <a href="#">HPD 2.1 EcoFlex NXT Gold - 1000 ppm</a>              |
| Environmental Claims Validation | <a href="#">EPD EcoFlex NXT</a>                                  |
| LEED Credit Potential           | LEED Eligible  |

## Warranties

Lifetime Limited Carpet Tile Warranty, Lifetime Limited Colorfastness to Light, 10 Year Limited Colorfastness to Atmospheric Contaminants, 10 Year Limited Stain Warranty, Lifetime Static



# Sabbatical

|              |   |
|--------------|---|
| Collection   | Learn and Live                            |
| Style Name   | Sabbatical                                |
| Style Number | GT433                                     |
| Product Type | Carpet Tile                               |
| Size         | 12" X 36"                                 |
| Construction | Tufted                                    |
| Installation | Half Lap, Brick Ashlar, Basket Weave, Pla |



| Feature              | Description                               |
|----------------------|---|
| Overall Thickness    | .244" (6.20 mm)                           |
| Backing Material     | EcoFlex NXT                               |
| Fiber Type           | Duracolor® Tricor Premium Nylon           |
| Dye Method           | Solution Dyed                             |
| Installation Methods | Half Lap, Brick Ashlar, Basket Weave, Pla |
| Stitches per Inch    | 13.8 (54.33 per 10cm)                     |
| Density              | 7578                                      |
| Tufted Pile Weight   | 20.00 oz/yd2 (678 g/m2)                   |
| Surface Texture      | Level Heathered Loop                      |

## Colorways



### Major

Color code: 159  
Style number: GT433



### Minor

Color code: 258  
Style number: GT433



### Extra Credit

Color code: 359  
Style number: GT433



### Semester

Color code: 458  
Style number: GT433



### Audit

Color code: 525  
Style number: GT433



### Elective

Color code: 558  
Style number: GT433



### Scholar

Color code: 655  
Style number: GT433



### Transcript

Color code: 755  
Style number: GT433



### Gpa

Color code: 977  
Style number: GT433



## Performance

| Feature                          | Description                    |
|----------------------------------|--------------------------------|
| Gauge                            | 1/12 (47.00 rows per 10 cm)    |
| Stain Release Technology         | Pass                           |
| Foot Traffic Recommendation TARR | Severe                         |
| Flammability                     | ASTM E 648 Class 1 (Glue Down) |
| Smoke Density                    | ASTM E 662 Less than 450       |
| Static Propensity                | AATCC-134 Under 3.5 KV         |
| Soil Release Technology          | EcoSentry Soil Protection      |

## Sustainability

| Feature                         | Description  |
|---------------------------------|--|
| Beyond Carbon Neutral           | This product is 100% carbon neutral plus an additional 5% offset |
| Carbon Handprint                | -0.066 kg CO2e/ft2   |
| Embodied Carbon                 | 1.33 kg CO2e/ft2   |
| Total Recycled Content          | 58%  |
| Pre-Consumer Recycled Content   | 58%  |
| NSF 140                         | <a href="#">EcoFlex NXT - NSF 140 Gold</a>                       |
| Indoor Air Quality              | <a href="#">GLP 1171</a>   |
| TVOC Range                      | 0.5 mg/m3 or less  |
| Red List Free                   | True   |
| Declare Label                   | Nylon Modular Carpet on EcoFlex NXT                              |
| Mindful Materials               | Participates in Mindful Materials Library                        |
| Take Back Program               | <a href="#">ReCover Program</a>                                  |
| Health Product Declaration      | <a href="#">HPD 2.1 EcoFlex NXT Gold - 1000 ppm</a>              |
| Environmental Claims Validation | <a href="#">EPD EcoFlex NXT</a>                                  |
| LEED Credit Potential           | LEED Eligible  |

## Warranties

Lifetime Limited Carpet Tile Warranty, Lifetime Limited Duracolor Stain Warranty, Lifetime Static



# Write Direction

|              |   |
|--------------|---|
| Collection   | Get Smart                                       |
| Style Name   | Write Direction                                 |
| Style Number | GT318   |
| Product Type | Carpet Tile                                     |
| Size         | 12" X 36"                                       |
| Construction | Tufted  |
| Installation | Monolithic, Half Lap, Brick Ashlar, Basketweave |

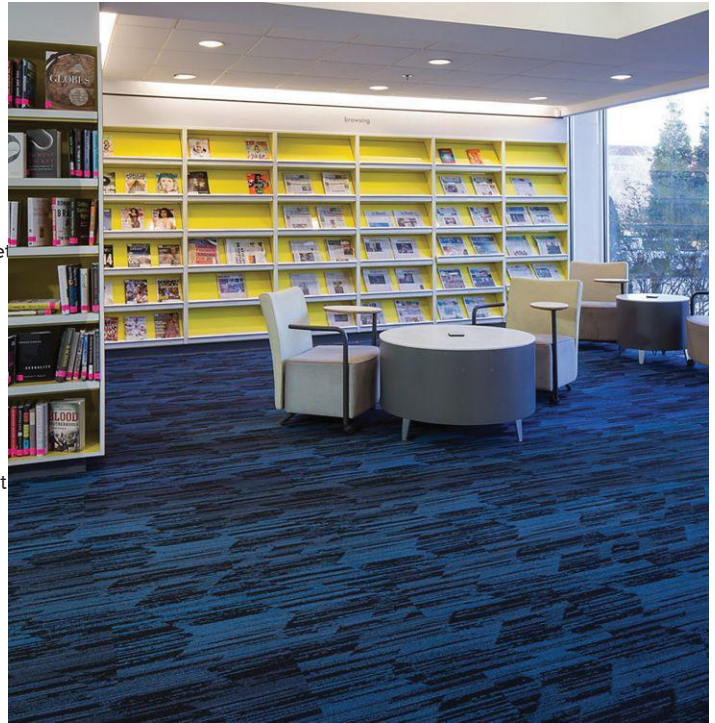

| Feature              | Description                                     |
|----------------------|---|
| Backing Material     | EcoFlex NXT                                     |
| Fiber Type           | Duracolor® Tricor Premium Nylon                 |
| Dye Method           | Solution Dyed                                   |
| Installation Methods | Monolithic, Half Lap, Brick Ashlar, Basketweave |
| Stitches per Inch    | 11 (43.31 per 10cm)                             |
| Density              | 7534  |
| Tufted Pile Weight   | 18.00 oz/yd2 (610 g/m2)                         |
| Surface Texture      | Textured Patterned Loop                         |

# Colorways



### Cayenne

Color code: 263  
Style number: GT318



### Peacock

Color code: 566  
Style number: GT318



### Magic

Color code: 589  
Style number: GT318



### Greenery

Color code: 661  
Style number: GT318



### Hound

Color code: 849  
Style number: GT318



### Subtle

Color code: 861  
Style number: GT318



### Everglade

Color code: 949  
Style number: GT318



### Metro

Color code: 957  
Style number: GT318



### Cocoa

Color code: 969  
Style number: GT318



### Mystic

Color code: 989  
Style number: GT318



## Performance

| Feature                          | Description                    |
|----------------------------------|--------------------------------|
| Gauge                            | 1/12 (47.00 rows per 10 cm)    |
| Stain Release Technology         | Pass                           |
| Foot Traffic Recommendation TARR | Severe                         |
| Flammability                     | ASTM E 648 Class 1 (Glue Down) |
| Smoke Density                    | ASTM E 662 Less than 450       |
| Static Propensity                | AATCC-134 Under 3.5 KV         |
| Soil Release Technology          | EcoSentry Soil Protection      |

## Sustainability

| Feature                         | Description  |
|---------------------------------|--|
| Beyond Carbon Neutral           | This product is 100% carbon neutral plus an additional 5% offset |
| Carbon Handprint                | -0.062 kg CO <sub>2</sub> e/ft <sup>2</sup>                      |
| Embodied Carbon                 | 1.24 kg CO <sub>2</sub> e/ft <sup>2</sup>                        |
| Total Recycled Content          | 57%  |
| Pre-Consumer Recycled Content   | 57%  |
| NSF 140                         | <a href="#">EcoFlex NXT - NSF 140 Gold</a>                       |
| Indoor Air Quality              | <a href="#">GLP 1171</a>   |
| TVOC Range                      | 0.5 mg/m <sup>3</sup> or less                                    |
| Red List Free                   | True   |
| Declare Label                   | Nylon Modular Carpet on EcoFlex NXT                              |
| Mindful Materials               | Participates in Mindful Materials Library                        |
| Take Back Program               | <a href="#">ReCover Program</a>                                  |
| Health Product Declaration      | <a href="#">HPD 2.1 EcoFlex NXT Gold - 1000 ppm</a>              |
| Environmental Claims Validation | <a href="#">EPD EcoFlex NXT</a>                                  |
| Global Green Tag                | GreenRate Level A, LCARate Silver Plus                           |
| LEED Credit Potential           | LEED Eligible  |

## Warranties

Lifetime Limited Carpet Tile Warranty, Lifetime Duracolor Stain Warranty, Lifetime Static

















# New Basics III

|              |                |
|--------------|----------------|
| Style Name   | New Basics III |
| Style Number | BC398          |
| Product Type | Broadloom      |
| Size         | 12Ft 00In      |
| Construction | Tufted         |
| Installation | Monolithic     |



| Feature              | Description             |
|----------------------|-------------------------|
| Backing Material     | Weldlok®                |
| Fiber Type           | ColorStrand® SD Nylon   |
| Dye Method           | Solution Dyed           |
| Installation Methods | Monolithic              |
| Stitches per Inch    | 7.67 (30.18 per 10cm)   |
| Density              | 5179                    |
| Tufted Pile Weight   | 20.00 oz/yd2 (678 g/m2) |
| Surface Texture      | Textured Heathered Loop |

## Colorways

|  |  |   |   |   |   |
|--|--|---|---|---|---|
|  | <b>Terra Clay</b><br>Color code: 374<br>Style number: BC398      |  | <b>Anodized Lapis</b><br>Color code: 559<br>Style number: BC398 |  | <b>Celestial</b><br>Color code: 589<br>Style number: BC398    |
|  | <b>Blarney Stone</b><br>Color code: 679<br>Style number: BC398   |  | <b>Forest</b><br>Color code: 689<br>Style number: BC398         |  | <b>Carbon Char</b><br>Color code: 719<br>Style number: BC398  |
|  | <b>Biscotti Crunch</b><br>Color code: 837<br>Style number: BC398 |  | <b>Earth</b><br>Color code: 879<br>Style number: BC398          |  | <b>Majolica Tin</b><br>Color code: 928<br>Style number: BC398 |
|  | <b>Quartz</b><br>Color code: 948<br>Style number: BC398          |  | <b>Smokestack</b><br>Color code: 964<br>Style number: BC398     |  | <b>Steel</b><br>Color code: 965<br>Style number: BC398        |
|  | <b>Mineralite</b><br>Color code: 978<br>Style number: BC398      |  | <b>Onyx</b><br>Color code: 989<br>Style number: BC398           |   |   |



## Performance

| Feature                          | Description                    |
|----------------------------------|--------------------------------|
| Gauge                            | 1/12 (47.00 rows per 10 cm)    |
| Stain Release Technology         | Pass                           |
| Foot Traffic Recommendation TARR | Severe                         |
| Flammability                     | ASTM E 648 Class 1 (Glue Down) |
| Smoke Density                    | ASTM E 662 Less than 450       |
| Static Propensity                | AATCC-134 Under 3.5 KV         |
| Soil Release Technology          | EcoSentry Soil Protection      |

## Sustainability

| Feature                         | Description  |
|---------------------------------|--|
| Beyond Carbon Neutral           | This product is 100% carbon neutral plus an additional 5% offset |
| Carbon Handprint                | -0.062 kg CO2e/ft2   |
| Embodied Carbon                 | 1.24 kg CO2e/ft2   |
| Total Recycled Content          | 57%  |
| Pre-Consumer Recycled Content   | 57%  |
| NSF 140                         | <a href="#">EcoFlex NXT - NSF 140 Gold</a>                       |
| Indoor Air Quality              | <a href="#">GLP 1171</a>   |
| TVOC Range                      | 0.5 mg/m3 or less  |
| Red List Free                   | True   |
| Declare Label                   | Nylon Modular Carpet on EcoFlex NXT                              |
| Mindful Materials               | Participates in Mindful Materials Library                        |
| Take Back Program               | <a href="#">ReCover Program</a>                                  |
| Health Product Declaration      | <a href="#">HPD 2.1 EcoFlex NXT Gold - 1000 ppm</a>              |
| Environmental Claims Validation | <a href="#">EPD EcoFlex NXT</a>                                  |
| Global Green Tag                | GreenRate Level A, LCARate Silver Plus                           |
| LEED Credit Potential           | LEED Eligible  |

## Warranties

Lifetime Limited Carpet Tile Warranty, Lifetime Duracolor Stain Warranty, Lifetime Static



# End Result

|              |               |
|--------------|---------------|
| Collection   | Of The Moment |
| Style Name   | End Result    |
| Style Number | BC288         |
| Product Type | Broadloom     |
| Size         | 12Ft 00In     |
| Construction | Tufted        |
| Installation | Monolithic    |

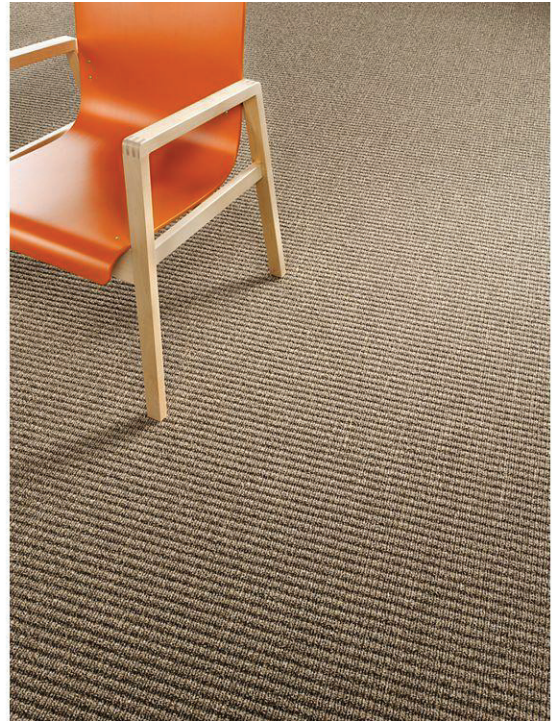

| Feature              | Description             |
|----------------------|-------------------------|
| Overall Thickness    | .287" (7.29 mm)         |
| Backing Material     | Weldlok®                |
| Fiber Type           | ColorStrand® SD Nylon   |
| Dye Method           | Solution Dyed           |
| Installation Methods | Monolithic              |
| Stitches per Inch    | 9.17 (36.09 per 10cm)   |
| Density              | 5438                    |
| Tufted Pile Weight   | 20.50 oz/yd2 (695 g/m2) |
| Surface Texture      | Textured Heathered Loop |

## Colorways



### Forward Bound

Color code: 7559  
Style number: BC288



### Jump Start

Color code: 7679  
Style number: BC288



### Self Expressions

Color code: 7714  
Style number: BC288



### Suit Yourself

Color code: 7822  
Style number: BC288



### Anything Goes

Color code: 7828  
Style number: BC288



### Go Forth

Color code: 7837  
Style number: BC288



### Artfully Done

Color code: 7838  
Style number: BC288



### Smart Choice

Color code: 7928  
Style number: BC288



### Style Shaper

Color code: 7958  
Style number: BC288



### Defining Moment

Color code: 7959  
Style number: BC288



### Checking In

Color code: 7978  
Style number: BC288





## Performance

| Feature                          | Description                    |
|----------------------------------|--------------------------------|
| Gauge                            | 1/12 (47.00 rows per 10 cm)    |
| Foot Traffic Recommendation TARR | Heavy                          |
| Flammability                     | ASTM E 648 Class 1 (Glue Down) |
| Smoke Density                    | ASTM E 662 Less than 450       |
| Static Propensity                | AATCC-134 Under 3.5 KV         |
| Pattern Repeat                   | 0.6"W X 0.75"L                 |
| Soil Release Technology          | EcoSentry Soil Protection      |

## Sustainability

| Feature                         | Description  |
|---------------------------------|--|
| Beyond Carbon Neutral           | This product is 100% carbon neutral plus an additional 5% offset |
| Carbon Handprint                | -0.046 kg CO2e/ft2   |
| Embodied Carbon                 | 0.93 kg CO2e/ft2   |
| Total Recycled Content          | 51%  |
| Pre-Consumer Recycled Content   | 51%  |
| NSF 140                         | <a href="#">Weldlok - NSF 140 Gold</a>                           |
| Indoor Air Quality              | <a href="#">GLP 8216</a>   |
| TVOC Range                      | 0.5 mg/m3 - 5.0 mg/m3  |
| Red List Free                   | True   |
| Declare Label                   | Broadloom Carpet on Weldlok®                                     |
| Mindful Materials               | Participates in Mindful Materials Library                        |
| Take Back Program               | <a href="#">ReCover Program</a>                                  |
| Health Product Declaration      | <a href="#">HPD 2.1 Weldlok - 1000 ppm</a>                       |
| Environmental Claims Validation | <a href="#">EPD Tufted Broadloom on Weldlok</a>                  |
| LEED Credit Potential           | LEED Eligible  |

## Warranties

Lifetime Limited Wear Warranty, Lifetime Limited Colorfastness to Light, 10 Year Limited Colorfastness to Atmospheric Contaminants, 10 Year Limited Stain Warranty, Lifetime Static











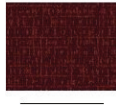

# Gathered Style

|              |                |
|--------------|----------------|
| Collection   | Intertwined    |
| Style Name   | Gathered Style |
| Style Number | BC404          |
| Product Type | Broadloom      |
| Size         | 12Ft 00In      |
| Construction | Tufted         |
| Installation | Monolithic     |



| Feature              | Description                   |
|----------------------|-------------------------------|
| Backing Material     | Unibond® Plus                 |
| Fiber Type           | ColorStrand® SD Nylon         |
| Dye Method           | Solution Dyed                 |
| Installation Methods | Monolithic                    |
| Stitches per Inch    | 10.33 (40.68 per 10cm)        |
| Density              | 9961                          |
| Tufted Pile Weight   | 28.50 oz/yd2 (966 g/m2)       |
| Surface Texture      | Textured Patterned Cut & Loop |

## Colorways

|   |  |   |
|---|--|---|
| <br><b>Overlay</b><br>Color code: 141<br>Style number: BC404  | <br><b>Poplin</b><br>Color code: 365<br>Style number: BC404   | <br><b>Trim</b><br>Color code: 553<br>Style number: BC404    |
| <br><b>Stitches</b><br>Color code: 641<br>Style number: BC404 | <br><b>Blending</b><br>Color code: 858<br>Style number: BC404 | <br><b>Thimble</b><br>Color code: 859<br>Style number: BC404 |
| <br><b>Gather</b><br>Color code: 869<br>Style number: BC404   | <br><b>Facing</b><br>Color code: 889<br>Style number: BC404   | <br><b>Thread</b><br>Color code: 945<br>Style number: BC404  |
| <br><b>Binding</b><br>Color code: 948<br>Style number: BC404  | <br><b>Needle</b><br>Color code: 965<br>Style number: BC404   | <br><b>Pique</b><br>Color code: 989<br>Style number: BC404   |



## Performance

| Feature                          | Description                    |
|----------------------------------|--------------------------------|
| Gauge                            | 1/12 (47.00 rows per 10 cm)    |
| Foot Traffic Recommendation TARR | Heavy                          |
| Flammability                     | ASTM E 648 Class 1 (Glue Down) |
| Smoke Density                    | ASTM E 662 Less than 450       |
| Static Propensity                | AATCC-134 Under 3.5 KV         |
| Pattern Repeat                   | 18"W X 12.8"L                  |
| Soil Release Technology          | EcoSentry Soil Protection      |

## Sustainability

| Feature                         | Description  |
|---------------------------------|--|
| Beyond Carbon Neutral           | This product is 100% carbon neutral plus an additional 5% offset |
| Carbon Handprint                | -0.058 kg CO2e/ft2   |
| Embodied Carbon                 | 1.15 kg CO2e/ft2   |
| Total Recycled Content          | 39%  |
| Pre-Consumer Recycled Content   | 39%  |
| NSF 140                         | <a href="#">Unibond Plus - NSF 140 Gold</a>                      |
| Indoor Air Quality              | <a href="#">GLP 3802</a>   |
| TVOC Range                      | 0.5 mg/m3 - 5.0 mg/m3  |
| Red List Free                   | True   |
| Declare Label                   | Broadloom Carpet on Unibond® Plus                                |
| Mindful Materials               | Participates in Mindful Materials Library                        |
| Take Back Program               | <a href="#">ReCover Program</a>                                  |
| Health Product Declaration      | <a href="#">HPD 2.1 Unibond Plus - 1000 ppm</a>                  |
| Environmental Claims Validation | <a href="#">EPD Unibond Plus</a>                                 |
| LEED Credit Potential           | LEED Eligible  |

## Warranties

Lifetime Limited Unibond® Plus Warranty, Lifetime Limited Colorfastness to Light, 10 Year Limited Colorfastness to Atmospheric Contaminants, 10 Year Limited Stain Warranty, Lifetime Static



# Trail Mix

|              |              |
|--------------|--------------|
| Collection   | Explorations |
| Style Name   | Trail Mix    |
| Style Number | BC333        |
| Product Type | Broadloom    |
| Size         | 12Ft 00In    |
| Construction | Tufted       |
| Installation | Monolithic   |

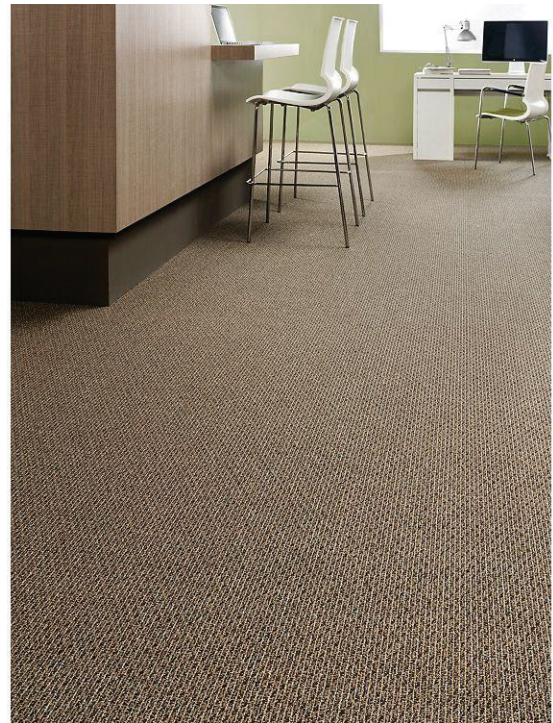

| Feature              | Description             |
|----------------------|-------------------------|
| Backing Material     | Weldlok®                |
| Fiber Type           | ColorStrand® SD Nylon   |
| Dye Method           | Solution Dyed           |
| Installation Methods | Monolithic              |
| Stitches per Inch    | 9 (35.43 per 10cm)      |
| Density              | 5714                    |
| Tufted Pile Weight   | 22.00 oz/yd2 (746 g/m2) |
| Surface Texture      | Textured Patterned Loop |

## Colorways



### Mixed Infusion

Color code: 7558  
Style number: BC333



### Urban Indigo

Color code: 7579  
Style number: BC333



### Golden Umbers

Color code: 7831  
Style number: BC333



### Faded Canvas

Color code: 7848  
Style number: BC333



### Mixed Woods

Color code: 7868  
Style number: BC333



### Layered Earth

Color code: 7968  
Style number: BC333



### Grounded Char

Color code: 7989  
Style number: BC333



## Performance

| Feature                          | Description                    |
|----------------------------------|--------------------------------|
| Gauge                            | 1/10 (39.37 rows per 10 cm)    |
| Foot Traffic Recommendation TARR | Heavy                          |
| Flammability                     | ASTM E 648 Class 1 (Glue Down) |
| Smoke Density                    | ASTM E 662 Less than 450       |
| Static Propensity                | AATCC-134 Under 3.5 KV         |
| Pattern Repeat                   | 1.2"W X 1.2"L                  |
| Soil Release Technology          | EcoSentry Soil Protection      |

## Sustainability

| Feature                         | Description  |
|---------------------------------|--|
| Beyond Carbon Neutral           | This product is 100% carbon neutral plus an additional 5% offset |
| Carbon Handprint                | -0.046 kg CO2e/ft2   |
| Embodied Carbon                 | 0.93 kg CO2e/ft2   |
| Total Recycled Content          | 51%  |
| Pre-Consumer Recycled Content   | 51%  |
| NSF 140                         | <a href="#">Weldlok - NSF 140 Gold</a>                           |
| Indoor Air Quality              | <a href="#">GLP 3802</a>   |
| TVOC Range                      | 0.5 mg/m3 - 5.0 mg/m3  |
| Red List Free                   | True   |
| Declare Label                   | Broadloom Carpet on Weldlok®                                     |
| Mindful Materials               | Participates in Mindful Materials Library                        |
| Take Back Program               | <a href="#">ReCover Program</a>                                  |
| Health Product Declaration      | <a href="#">HPD 2.1 Weldlok - 1000 ppm</a>                       |
| Environmental Claims Validation | <a href="#">EPD Tufted Broadloom on Weldlok</a>                  |
| LEED Credit Potential           | LEED Eligible  |

## Warranties

Lifetime Limited Wear Warranty, Lifetime Limited Colorfastness to Light, 10 Year Limited Colorfastness to Atmospheric Contaminants, 10 Year Limited Stain Warranty, Lifetime Static

















# In The Loop Tile

|              |   |
|--------------|---|
| Collection   | In The Loop                                     |
| Style Name   | In The Loop Tile                                |
| Style Number | BT309   |
| Product Type | Carpet Tile                                     |
| Size         | 24" X 24"                                       |
| Construction | Tufted  |
| Installation | Monolithic, Vertical Ashlar, Brick Ashlar, etc. |



| Feature              | Description                                     |
|----------------------|---|
| Overall Thickness    | .251" (6.38 mm)                                 |
| Backing Material     | Ecoflex Matrix                                  |
| Fiber Type           | ColorStrand® SD Nylon                           |
| Dye Method           | Solution Dyed                                   |
| Installation Methods | Monolithic, Vertical Ashlar, Brick Ashlar, etc. |
| Stitches per Inch    | 10.1 (39.76 per 10cm)                           |
| Density              | 6206  |
| Tufted Pile Weight   | 20.00 oz/yd2 (678 g/m2)                         |
| Surface Texture      | Textured Patterned Loop                         |

## Colorways

|   |   |   |
|---|---|---|
|  <p><b>Bombshell Red</b></p> <p>Color code: 7465<br/>Style number: BT309</p>  |  <p><b>Slaten Sky</b></p> <p>Color code: 7559<br/>Style number: BT309</p>    |  <p><b>Voltaic Blue</b></p> <p>Color code: 7575<br/>Style number: BT309</p>    |
|  <p><b>Twilight Dawn</b></p> <p>Color code: 7599<br/>Style number: BT309</p>  |  <p><b>Bamboo Sprout</b></p> <p>Color code: 7846<br/>Style number: BT309</p> |  <p><b>Stoney Pebble</b></p> <p>Color code: 7847<br/>Style number: BT309</p>   |
|  <p><b>Natural Hybrid</b></p> <p>Color code: 7858<br/>Style number: BT309</p> |  <p><b>Coffee Bean</b></p> <p>Color code: 7868<br/>Style number: BT309</p>   |  <p><b>Grounded Earth</b></p> <p>Color code: 7869<br/>Style number: BT309</p>  |
|  <p><b>Double Latte</b></p> <p>Color code: 7898<br/>Style number: BT309</p>   |  <p><b>Hammered Tin</b></p> <p>Color code: 7939<br/>Style number: BT309</p>  |  <p><b>Chameleon Mixer</b></p> <p>Color code: 7959<br/>Style number: BT309</p> |
|  <p><b>Burnished Iron</b></p> <p>Color code: 7968<br/>Style number: BT309</p> |  <p><b>Chimney Sweep</b></p> <p>Color code: 7969<br/>Style number: BT309</p> |  <p><b>Metal Works</b></p> <p>Color code: 7979<br/>Style number: BT309</p>     |



## Colorways



### Blackened Pearl

Color code: 7989  
Style number: BT309

## Performance

| Feature                          | Description                    |
|----------------------------------|--------------------------------|
| Gauge                            | 1/8 (31.50 rows per 10 cm)     |
| Foot Traffic Recommendation TARR | Heavy                          |
| Flammability                     | ASTM E 648 Class 1 (Glue Down) |
| Smoke Density                    | ASTM E 662 Less than 450       |
| Static Propensity                | AATCC-134 Under 3.5 KV         |
| Soil Release Technology          | EcoSentry Soil Protection      |

## Sustainability

| Feature                         | Description  |
|---------------------------------|--|
| Beyond Carbon Neutral           | This product is 100% carbon neutral plus an additional 5% offset |
| Carbon Handprint                | -0.063 kg CO2e/ft2   |
| Embodied Carbon                 | 1.27 kg CO2e/ft2   |
| Total Recycled Content          | 52%  |
| Pre-Consumer Recycled Content   | 52%  |
| NSF 140                         | <a href="#">EcoFlex Matrix - NSF 140 Gold</a>                    |
| Indoor Air Quality              | <a href="#">GLP 1171</a>   |
| TVOC Range                      | 0.5 mg/m3 or less  |
| Red List Free                   | True   |
| Declare Label                   | Nylon Modular Carpet on EcoFlex Matrix                           |
| Mindful Materials               | Participates in Mindful Materials Library                        |
| Take Back Program               | <a href="#">ReCover Program</a>                                  |
| Health Product Declaration      | <a href="#">HPD 2.1 EcoFlex Matrix - 1000 ppm</a>                |
| Environmental Claims Validation | <a href="#">EPD EcoFlex Matrix</a>                               |
| LEED Credit Potential           | LEED Eligible  |

## Warranties

Lifetime Limited Carpet Tile Warranty, Lifetime Limited Colorfastness to Light, 10 Year Limited Colorfastness to Atmospheric Contaminants, 10 Year Limited Stain Warranty, Lifetime Static







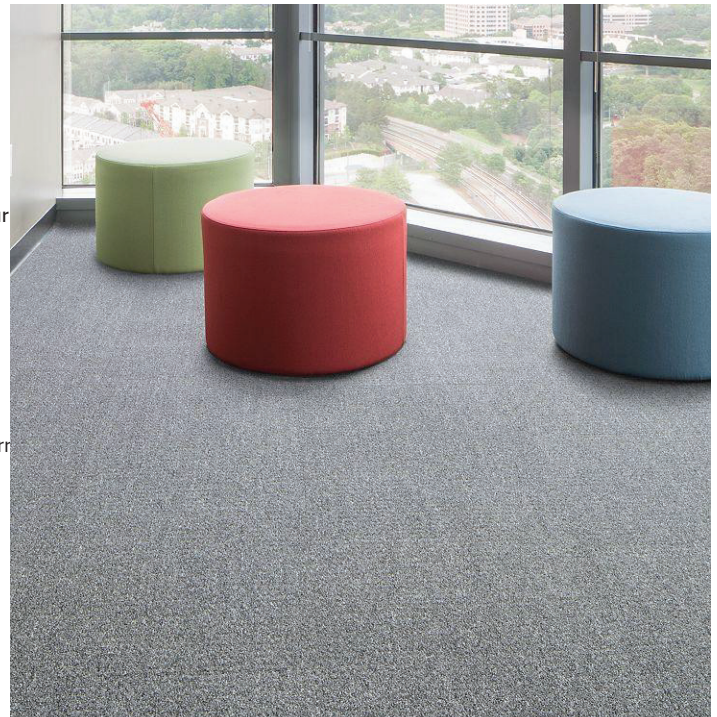









# New Basics III Tile

|              |   |
|--------------|---|
| Style Name   | New Basics III Tile                         |
| Style Number | BT400                                       |
| Product Type | Carpet Tile                                 |
| Size         | 24" X 24"                                   |
| Construction | Tufted                                      |
| Installation | Brick Ashlar, Vertical Ashlar, Quarter Turn |



| Feature              | Description                                 |
|----------------------|---|
| Backing Material     | EcoFlex Matrix                              |
| Fiber Type           | ColorStrand® SD Nylon                       |
| Dye Method           | Solution Dyed                               |
| Installation Methods | Brick Ashlar, Vertical Ashlar, Quarter Turn |
| Stitches per Inch    | 7 (27.56 per 10cm)                          |
| Density              | 5684  |
| Tufted Pile Weight   | 18.00 oz/yd2 (610 g/m2)                     |
| Surface Texture      | Textured Heathered Loop                     |

## Colorways

|   |   |   |
|---|---|---|
|  <p><b>Terra Clay</b></p> <p>Color code: 374<br/>Style number: BT400</p>      |  <p><b>Anodized Lapis</b></p> <p>Color code: 559<br/>Style number: BT400</p> |  <p><b>Celestial</b></p> <p>Color code: 589<br/>Style number: BT400</p>    |
|  <p><b>Blarney Stone</b></p> <p>Color code: 679<br/>Style number: BT400</p>   |  <p><b>Forest</b></p> <p>Color code: 689<br/>Style number: BT400</p>         |  <p><b>Carbon Char</b></p> <p>Color code: 719<br/>Style number: BT400</p>  |
|  <p><b>Biscotti Crunch</b></p> <p>Color code: 837<br/>Style number: BT400</p> |  <p><b>Earth</b></p> <p>Color code: 879<br/>Style number: BT400</p>          |  <p><b>Majolica Tin</b></p> <p>Color code: 928<br/>Style number: BT400</p> |
|  <p><b>Quartz</b></p> <p>Color code: 948<br/>Style number: BT400</p>          |  <p><b>Smokestack</b></p> <p>Color code: 964<br/>Style number: BT400</p>     |  <p><b>Steel</b></p> <p>Color code: 965<br/>Style number: BT400</p>        |
|  <p><b>Mineralite</b></p> <p>Color code: 978<br/>Style number: BT400</p>      |  <p><b>Onyx</b></p> <p>Color code: 989<br/>Style number: BT400</p>           |   |





## Performance

| Feature                          | Description                    |
|----------------------------------|--------------------------------|
| Gauge                            | 1/10 (39.37 rows per 10 cm)    |
| Foot Traffic Recommendation TARR | Heavy                          |
| Flammability                     | ASTM E 648 Class 1 (Glue Down) |
| Smoke Density                    | ASTM E 662 Less than 450       |
| Static Propensity                | AATCC-134 Under 3.5 KV         |
| Soil Release Technology          | EcoSentry Soil Protection      |

## Sustainability

| Feature                         | Description  |
|---------------------------------|--|
| Beyond Carbon Neutral           | This product is 100% carbon neutral plus an additional 5% offset |
| Carbon Handprint                | -0.059 kg CO2e/ft2   |
| Embodied Carbon                 | 1.18 kg CO2e/ft2   |
| Total Recycled Content          | 48%  |
| Pre-Consumer Recycled Content   | 48%  |
| NSF 140                         | <a href="#">EcoFlex Matrix - NSF 140 Gold</a>                    |
| Indoor Air Quality              | <a href="#">GLP 1171</a>   |
| TVOC Range                      | 0.5 mg/m3 or less  |
| Red List Free                   | True   |
| Declare Label                   | Nylon Modular Carpet on EcoFlex Matrix                           |
| Mindful Materials               | Participates in Mindful Materials Library                        |
| Take Back Program               | <a href="#">ReCover Program</a>                                  |
| Health Product Declaration      | <a href="#">HPD 2.1 EcoFlex Matrix - 1000 ppm</a>                |
| Environmental Claims Validation | <a href="#">EPD EcoFlex Matrix</a>                               |
| Global Green Tag                | GreenRate Level A, LCARate Silver Plus                           |
| LEED Credit Potential           | LEED Eligible  |

## Warranties

Lifetime Limited Carpet Tile Warranty, Lifetime Limited Colorfastness to Light, 10 Year Limited Colorfastness to Atmospheric Contaminants, 10 Year Limited Stain Warranty, Lifetime Static



# First Step II

|              |                            |
|--------------|----------------------------|
| Collection   | Tuff Stuff II              |
| Style Name   | First Step II              |
| Style Number | GT315                      |
| Product Type | Carpet Tile                |
| Size         | 24" X 24"                  |
| Construction | Tufted                     |
| Installation | Brick Ashlar, Quarter Turn |



| Feature              | Description                                       |
|----------------------|---|
| Backing Material     | EcoFlex NXT                                       |
| Installation Methods | Brick Ashlar, Quarter Turn                        |
| Stitches per Inch    | 8.5 (33.46 per 10cm)                              |
| Density              | 6739  |
| Tufted Pile Weight   | 38.00 oz/yd <sup>2</sup> (1288 g/m <sup>2</sup> ) |

## Colorways



### Walnut

Color code: 859  
Style number: GT315



### Cobalt

Color code: 955  
Style number: GT315



### Iron Ore

Color code: 983  
Style number: GT315



### Obsidian

Color code: 989  
Style number: GT315

## Performance

| Feature                          | Description               |
|----------------------------------|---------------------------|
| Foot Traffic Recommendation TARR | Severe                    |
| Soil Release Technology          | EcoSentry Soil Protection |



# Sustainability

| Feature                         | Description  |
|---------------------------------|--|
| Beyond Carbon Neutral           | This product is 100% carbon neutral plus an additional 5% offset |
| Carbon Handprint                | -0.103 kg CO2e/ft2   |
| Embodied Carbon                 | 2.06 kg CO2e/ft2   |
| Total Recycled Content          | 53%  |
| Pre-Consumer Recycled Content   | 53%  |
| NSF 140                         | <a href="#">EcoFlex NXT - NSF 140 Gold</a>                       |
| Indoor Air Quality              | GLP 1098   |
| TVOC Range                      | 0.5 mg/m3 or less  |
| Red List Free                   | True   |
| Mindful Materials               | Participates in Mindful Materials Library                        |
| Health Product Declaration      | <a href="#">HPD 2.1 EcoFlex NXT Gold - 1000 ppm</a>              |
| Environmental Claims Validation | <a href="#">EPD EcoFlex NXT</a>                                  |
| LEED Credit Potential           | LEED Eligible  |



# NuBroadlok® Premium Multi-Purpose Adhesive

## Technical Data Sheet (TDS)

NuBroadlok® Premium Multi-Purpose Adhesive is specially designed to install all Mohawk Group broadloom carpet products. NuBroadlok® Premium Multi-Purpose Adhesive is non-flammable and has low odor and low VOC's which makes it ideal for use in schools, health care facilities, public buildings, and anywhere odor is a concern. NuBroadlok® Premium Multi-Purpose Adhesive is CRI Green Label Plus™ approved and meets or exceeds California SCQAMD Rule 1168.

**Features & Benefits**

- Quick tack
- Aggressive bond
- Low in odor and VOC's
- CRI Green Label Plus™ certified



### USE

For all Mohawk Group broadloom carpet products Interior residential (rental apartments, condominiums, homes). Interior commercial (office buildings, hotel rooms, hallways, restaurant dining areas). Interior institutional (hospital, schools, universities, libraries government buildings).

### SUBFLOOR PREPARATION

All substrates must be structurally sound, dry, solid and stable. The substrate should be clean and free of dust, dirt, oil, grease, paint, curing agents, concrete sealers, loosely bonded toppings, loose particles, old adhesive residues, and any other substance or condition that may prevent or reduce adhesion. All surfaces must be level, even, flat and smooth. Concrete floors must be fully cured and dry. Calcium Chloride Moisture Test (ASTM F1869) results must not exceed 5.0 lbs. In-Situ relative humidity reading (ASTM F2170) must not exceed 80% and pH must be between 5.0 and 9.0.

### SUITABLE SUBSTRATES

Exterior-grade plywood, Group 1, CC type  
Other approved wood underlayments (per manufacturer recommendations).  
Concrete and properly prepared cement terrazzo.  
Cement-based self-leveling underlayments and patching compounds.  
Embossing levelers applied over existing, properly prepared and fully bonded ceramic tile and fully bonded vinyl composition tile (VCT) – one layer only.  
Properly prepared and primed gypsum underlayments that meet the ASTM F2419 requirements for compressive strength.

### NOTE:

When installing Mohawk Group broadloom carpets over old cutback adhesive residue, use Mohawk Group OptiSeal™ as a barrier. Following instructions for use, apply the OptiSeal™ only after the cutback adhesive is mechanically scraped to a smooth minimum residue. Do not use over surfaces that have been treated with chemical adhesive removers.

Consult Mohawk Group's Technical Services

Department for installation recommendations regarding substrates and conditions not listed.

### APPLICATION

Read all installation instructions thoroughly before installation. Site conditions and floor preparation requirements must comply with those specified by the Mohawk Group Installation Guidelines. The installation site must be acclimated with HVAC in operation. The jobsite, substrate, carpet and adhesive must be conditioned at a temperature of 65°F – 85°F and ambient humidity of 65% maximum for at least 48 hours before and during the installation.

When installation is complete the jobsite must be maintained at normal service temperature and humidity. If these conditions are not attainable, contact Mohawk Group Technical Services. Use the appropriate notched trowel (see "Typical Trowels and Approximate Coverages" section). Spread adhesive evenly over the subfloor, keeping the trowel at a 45° angle to the subfloor. Install flooring in strict accordance with the Mohawk Group's installation guidelines. Roll the flooring with a 75 – 100 lb. roller across the width and length of the flooring surface.

### OPEN TIME

Open time is totally dependent upon site and slab conditions but under normal circumstances expect it to be between 20 to 30 minutes. High humidity and cold, and sealed or impervious substrates will extend open times.

### CLEAN UP

Promptly clean any adhesive from the flooring material's surface with water while the adhesive is still fresh/wet. Clean tools with water while the adhesive is still fresh/wet. Use mineral spirits once dried. Use caution with mineral spirits, which may be harmful to some materials. DO NOT APPLY SOLVENT DIRECTLY TO THE FLOORING MATERIAL.

### SHELF LIFE

Two years when stored in original, unopened packaging at 73°F (23°C).

**COVERAGE****Broadloom Backings:**

1/8" x 1/8" x 1/8" U-notched trowel 8 – 10sy/  
gallon or 32 – 40sy/4 gallon pail

**Woven Products**

1/8" x 1/8" x 1/16" V-notched trowel: 8 – 10sy/  
gallon or 32 – 40sy/4 gallon pail

**Double Stick (Carpet to Pad)**

1/8" x 1/8" x 1/16" U-notched trowel: 20 –  
28sy/4 gallon pail

**PROTECT FROM FREEZING**

Protect containers from freezing in transit and storage. Provide for heated storage on site and deliver all materials at least 24 hours before work begins.

**LIMITATIONS**

Do not install over any substrates containing asbestos. For interior installations only. Do not install when the moisture vapor emission rate (MVER) exceeds 5 lbs. per 1,000 sq. ft. per 24 hours, when using the anhydrous calcium chloride test (ASTM F1869).

Do not install when the relative humidity (RH) of the concrete slab exceeds 80% (ASTM F2170).

Use only when the substrate temperature is between 65° F and 85° F.

pH reading should be a maximum of 9.0.

Building owners should be advised of Mohawk Group flooring installation guidelines for climate control settings (temperature and humidity). These conditions must be monitored and kept constant in order to ensure the overall performance and long-term success of the installation.

**MIXING**

Ready to use; no mixing is necessary.

NOTE: Choose all appropriate safety equipment before use. Refer to Material Safety Data Sheet (MSDS) for more information.

Please feel free to contact the Technical Services Department at 800.833.6954 for further information.



# Mohawk EnPress®

## Carpet Tile Adhesive



**Features & Benefits**

- Quick Tack
- Aggressive Bond
- Superior Shear Strength

Mohawk EnPress® carpet tile pressure sensitive adhesive is specially designed to install Mohawk Group carpet tiles with:

- EcoFlex ICT
- EcoFlex Matrix
- EcoFlex AIR
- EcoFlex NXT

EnPress® pressure sensitive adhesive is nonflammable and has low odor and “zero” calculated VOC’s, which makes it ideal for use in schools, healthcare facilities, public buildings, and anywhere odor is a concern.

EnPress® pressure sensitive adhesive is CRI Green Label Plus™ certified. This adhesive is not photochemically reactive as defined by California Rules 102 and 443 and also meets or exceeds VOC emission levels set by California SCAQMD Rule 1168. This adhesive contains MicroSept™ broad spectrum antimicrobial protection.

**MOISTURE WARRANTY** with Enpress Adhesive:

EcoFlex ICT  
80 % RH and 9 pH

EcoFlex NXT  
95 % RH and 12 pH

EcoFlex NXT AIR  
99% RH and 12 pH

EcoFlex Matrix  
95 % RH and 12 pH

**SPREAD RATE:**

EcoFlex ICT, NXT & Matrix  
140-160 sy per 4 gallons with a 3/8" nap roller

EcoFlex AIR  
100-120 sy per 4 gallons with a  
1/16"x 1/32" x 1/32" U-Notch Trowel

**PACKAGING:**

- Available in 4 gallon pails
- 48 pails per pallet



# FLEXLOK+

FlexLok+ tab system virtually eliminates harmful VOC's, this odorless dry installation system can be used in place of the traditional wet spread adhesives method. This system is performance without compromise and can be installed on any substrate. FlexLok provides a faster install with the flexibility of a floating modular floor with no glue.



## PERFORMANCE

- Exceeds all performance expectations without compromise
- FlexLok+ works with all Mohawk modular products with the exception of Walk Off Tile and EcoFlex Air products

## SUSTAINABILITY

- HPD and CRI Green Label Certified
- Minimal VOCs for increased indoor air quality

## INSTALLATION

- Install a flexible floating floor, no glue on the subfloor
- Install on any substrate (VCT, wood, etc.)
- FlexLok+ adhesive will not dry out so installation can be installed at your own pace
- Can be installed as long as there are no visible signs of moisture



### Install Methods – Tile 24x24

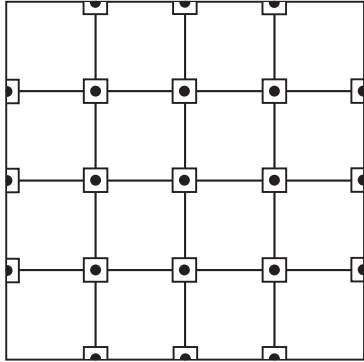

#### Quarter Turn, Monolithic, and Multi-Directional

Lay anchor rows and place a FlexLok+ tab at every joint. Install remaining carpet tiles using a step method, placing FlexLok+ tabs at each joint. Place a FlexLok+ tab at every joint around the perimeter of the room.

### Install Methods – Tile 24x24

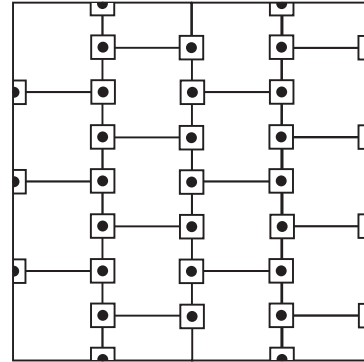

#### Brick and Ashlar

Lay anchor rows and place a FlexLok+ tab at every joint. Install remaining carpet tiles, placing FlexLok+ tabs as illustrated in the diagram. Place a FlexLok+ tab at every joint around the perimeter of the room.

### Install Methods – Plank 12x36

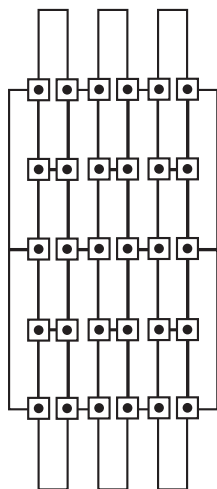

#### All Install Methods

Lay anchor rows and place a FlexLok+ tab at every joint. Install carpet using a step method placing a FlexLok+ tab at every corner.

### Install Methods – Plank 12x36

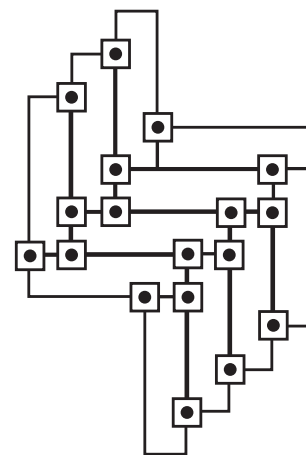

#### All Install Methods

Must be used in middle of length as well as four corners.

NOTE: Included above are recommended methods of installation most frequently used. Additional installation methods may be available based on product selection.